

**ISO 9001 certified fittings
And valves Manufacturer**

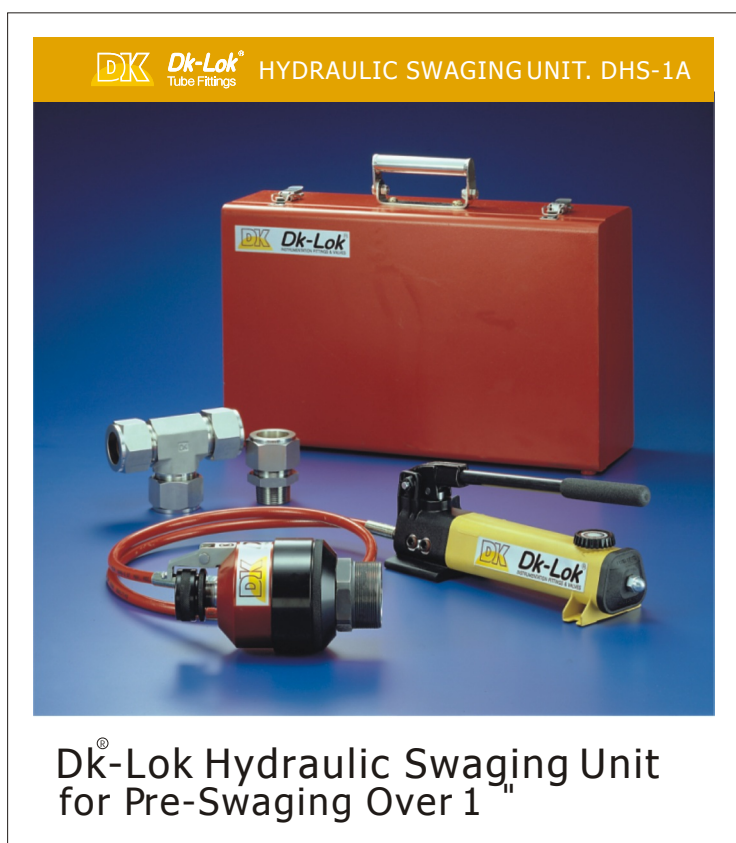

Dk-Lok® Tube Fittings

Catalog No. 01-4
January 2003.



Dk-Lok Hydraulic Swaging Unit
for Pre-Swaging Over 1"



Lloyd's Register
TYPE APPROVED

LR Type Approval Certificate

This is to certify that the undernoted product has been tested with satisfactory results in accordance with the relevant requirements of the LR Type Approval System.

This certificate is issued to:

PRODUCER DK Tech Co., Ltd.
PLACE OF PRODUCTION 568-17, Kwebup-dong, Sasang-gu, Pusan, 617-060 Korea
DESCRIPTION Stainless steel double ferrule compression type tube fittings, inch and metric sizes
TYPE DK-LOK Tube Fitting
APPLICATION High pressure tube connections for use in marine, offshore and industrial piping systems with hydraulic system fluids, fuel oil, lubricating oil, fresh water, salt water, sanitary, gas, steam and condensate.
DESIGN CODE LR Rules and Regulations for the Classification of Ships, Part 5, Chapter 12
 JIS B 2351 - 1990: 25 MPa bite type tube fittings for hydraulic use

RATING		Imperial Tubing-	Nominal pressure ratings (psi)
		Tube O.D. (inch)	
		1/8"	8,500 to 10,900
		3/16"	5,400 to 10,200
		1/4"	4,000 to 10,200
		5/16"	4,000 to 8,600
		3/8"	3,300 to 6,500
		3/4"	2,400 to 5,800
		7/8"	2,000 to 4,700
		1"	2,400 to 4,700
		1-1/4"	2,400 to 4,900
		1-1/2"	2,400 to 4,900
		2"	2,000 to 3,600

Certificate No. 01/10047
 Issue Date 28 June 2001
 Expiry Date 27 June 2006
 Sheet 1 of 2

 N. Terashita



Lloyd's Register of Shipping
71 Fenchurch Street, London EC3M 4BS

THIS DOCUMENT IS SUBJECT TO THE TERMS AND CONDITIONS OVERLEAF



Lloyd's Register
TYPE APPROVED

RATING (Continued)	Metric Tubing:	Nominal pressure ratings (psi)
	Tube O.D.(mm)	
	3	10,800 to 15,300
	4	7,900 to 14,400
	6	5,000 to 12,700
	8	4,700 to 9,300
	10	3,700 to 7,300
	12	3,000 to 7,300
	16	2,500 to 6,800
	18	2,800 to 6,700
	20	2,500 to 6,000
	22	2,300 to 5,400
	25	2,000 to 5,200
	28	2,600 to 4,800
	32	2,300 to 4,800
	38	2,000 to 4,500

Pressure-temperature ratings : see the producer's catalogue

OTHER CONDITIONS

- The fittings are to be installed in accordance with the manufacturer's instructions.
- Attention is drawn to Section 3.6 of IMO MSC/Circular.851 - Guidelines on Engine-Room Oil Fuel Systems which describes that compression couplings require careful attention to tightening procedures and torques to avoid leaks or damage to the pipe when subjected to overtightening and they should not be used in the fuel supply line of the (oil engine) injection pumps and spill system.

"This Certificate is not valid for equipment, the design, ratings or operating parameters of which have been varied from the specimen tested. The manufacturer should notify LR of any modification or changes to the equipment in order to obtain a valid certificate."

The attached Design Appraisal Document No. 01/10047 and its supplementary Type Approval Terms and Conditions form part of this Certificate.

Certificate No. 01/10047
 Issue Date 28 June 2001
 Expiry Date 27 June 2006
 Sheet 2 of 2

 N. Terashita



Lloyd's Register of Shipping
71 Fenchurch Street, London EC3M 4BS

THIS DOCUMENT IS SUBJECT TO THE TERMS AND CONDITIONS OVERLEAF



Germanischer Lloyd

Type Approval Certificate

This is to certify that the undernoted product(s) has/have been tested in accordance with the relevant requirements of the GL Type Approval System.

Certificate No. 40 505 - 01 HH
 Company Dk Tech Co., Ltd.
 568-17 Kwebup-dong, Sasang-gu
 Busan 617-060, Korea

Product Description PIPE UNIONS
 Type Dk-Lok TUBE FITTINGS

Environmental Category None

Technical Data / Range of Application

Material:	Stainless Steel		
Elastomere seals:	NBR	FPM	PTFE
Temperature range [°C]	-40 to 100	-20 to 200	-60 to 240
Nominal pressure PN [bar]:	According to page 2 of this certificate		

RANGE OF APPLICATION

- Piping systems on ships and other structures classed by Germanischer Lloyd.
- Max. allowable working pressure acc. to temperature de-rating factors specified in the catalogue no. 01-2
- The selection of the pipe unions for the corresponding service and the right installation are to be in accordance with the instructions of the manufacturer.

LIMITATIONS

Pipe unions with elastomer seals are not approved within machinery spaces for the use in fuel-, lubricating-, hydraulic oil, sea water and bilge piping systems. Threaded bulkhead pipe unions are not approved through watertight bulkheads.

Test Standard • Regulations for the Performance of Type Tests, Part 6-Test Requirements for Mechanical Components and Equipment.

Documents • Test reports of tests carried out from 11.04.01 to 18.05.01
 • Catalogue No. 01-2

Valid until 2006-06-26
 Page 1 of 2
 File No. ILC.05
 Hamburg, 2001-06-27



 D. Roßmanith

 H. Markus



Germanischer Lloyd

This certificate is issued on the basis of "Regulations for the Performance of Type Tests, Part 0, Procedure".



Germanischer Lloyd

Type Approval Certificate

This is to certify that the undernoted product(s) has/have been tested in accordance with the relevant requirements of the GL Type Approval System.

Certificate No. 40 505 - 01 HH

TECHNICAL DATA

Tube O.D. [inches]	Nominal Pressure PN [bar]
1/8"	766,0
3/16"	717,0
1/4"	717,0
5/16"	562,0
3/8"	457,0
1/2"	436,0
5/8"	422,0
3/4"	408,0
7/8"	330,0
1"	330,0
1 1/4"	337,0
1 1/2"	345,0
2"	253,0

Valid until 2006-06-26
 Page 2 of 2
 File No. ILC.05
 Hamburg, 2001-06-27

 D. Roßmanith

 H. Markus



Germanischer Lloyd

This certificate is issued on the basis of "Regulations for the Performance of Type Tests, Part 0, Procedure".



01-BK218882-PDA
CERTIFICATE NUMBER

27 MAR. 2001
DATE

Pusan
ABS TECHNICAL OFFICE

CERTIFICATE OF Product Design Assessment

This is to Certify **DK TECH CO., LTD.**
(COMPANY)

that a representative of this Bureau did, at the request of the above noted Company, assess design plans and data for the below listed product. This assessment is a representation by the Bureau as to the degree of compliance the design exhibits with applicable sections of the Rules. This assessment does not waive certification or classification procedures required by ABS Rules for products to be installed in ABS classed vessels or facilities. This certificate, by itself, does not reflect that the product is Type Approved. The scope and limitations of this assessment are detailed on the pages attached to this certificate; and it will remain valid for five years from the date of issue or until the Rules or specifications used in the assessment are revised (whichever occurs first).

PRODUCT: **DK-LOK & BITE TYPE FITTINGS**
MODEL: **SEE PDA/ Listing Format**
ABS RULE: **4-6-2/5.5.6 of the 2001 Rules**
OTHER STANDARD: **JIS B2351**

AMERICAN BUREAU OF SHIPPING
Yun Kang Sung
(ENGINEER)
Yun Kang Sung

NOTE: This certificate evidences compliance with one or more of the Rules, Guides, standards or other criteria of American Bureau of Shipping or a statutory, industrial or manufacturer's standard and is issued solely for the use of the Bureau, its committees, its clients or other authorized entities. Any significant changes to the aforementioned product without ABS approval will result in this certificate becoming null and void. This certificate is governed by the terms and conditions on the reverse side hereof.

TX1000_179-PDA0300 A4 1000



CERTIFICATE NUMBER 01-BK55619-X

PLANT LOCATION PUSAN, KOREA
PORT OFFICE PUSAN, KOREA

CERTIFICATE OF Product Type Approval

This is to Certify **DK TECH CO., LTD.**

that a representative of this Bureau did, at the request of the Company, attend their facilities on the date and location noted above, in order to carry out survey of the facilities and associated quality procedures. The facility is considered capable of manufacturing a product which meets the designated standards. The product listed on the Attachment is eligible to be placed on this Bureau's *List of Type Approved Products*, subject to annual facility surveys by a representative of this Bureau and renewal of this Certificate after five (5) years.

PRODUCT DESCRIPTION **TUBE FITTING**
ISSUE DATE **13 APRIL 2001** EXPIRATION DATE **13 APRIL 2006**
SURVEYOR'S SIGNATURE *Yong Soo Yoon*
SURVEYOR'S NAME IN TYPE **YONG SOO YOON**

FIRST ANNUAL ENDORSEMENT _____
SECOND ANNUAL ENDORSEMENT _____
THIRD ANNUAL ENDORSEMENT _____
FOURTH ANNUAL ENDORSEMENT _____

NOTE: This certificate evidences compliance with one or more of the Rules, Guides, standards or other criteria of American Bureau of Shipping or a statutory, industrial or manufacturer's standard and is issued solely for the use of the Bureau, its committees, its clients or other authorized entities. This certificate is governed by the terms and conditions on the reverse side hereof.

TX0100_021-CTAC02 A4 1000



DET NORSKE VERITAS TYPE APPROVAL CERTIFICATE

CERTIFICATE NO. P-11094
This Certificate consists of 4 pages

This is to certify that the
Pipe Couplings, Bite and Compression Type
with type designation(s)
DK-LOK: DU, DUR, DLU, DTU, DBU, DMC-N, DMC-R, DMC-G, DOM, DBMC, DLMA, DLMB, DRTM, DBTM, DFC, DGC, DBFC, DLF, DRTF, DBTF, DR, DBR, DAM, DAF, DFU, DBFU, DFA, DWC, DLW, DSWC, DLSW, DPA, DCA, DN, DFF, DFB

Manufactured by
DK Tech Co., Ltd.
Pusan 617-060, Republic of Korea

is found to comply with
Det Norske Veritas' Interpretation of SOLAS 1974 Convention as Amended
Det Norske Veritas' Standards for Certification 2.9 No. 102

Application
May be used for: hydraulic oil, fuel and lube oil (not high-pressure fuel oil injection), compressed air, steam and condensate, fresh and sea water, sanitary systems

Temperature range: -20°C to 300°C
Max. working press.: Dep. on size and temp., see cert.
Sizes: For pipe O.D. 6mm to 38mm - 1/4" to 2", see certificate

Place and date
Hovik, 2001-11-15
for DET NORSKE VERITAS AS
Kjell Folge
Kjell Folge
Head of Section



Local Office
DNV Pusan District Office

This Certificate is valid until
2004-12-31
Kristian Lindelof
Kristian Lindelof
Surveyor

Notice: This Certificate is subject to terms and conditions overleaf. Any significant change in design or construction may render this Certificate invalid.

DET NORSKE VERITAS AS VERITASVEIEN 1, 1322 HOVIK, NORWAY TEL: (+47) 67 57 99 00 FAX: (+47) 67 57 99 11
Form No.: 20.90a Issue: January 98 Page 1 of 4



Certificate No: C 142 - 109

Certificate of Approval

Awarded to
DK Tech Co., Ltd.
568-17, Kewapob-Dong, Sasang-Gu, Pusan, KOREA.

Small & Medium Industry Certification Center certify that the Quality Management System of the above supplier has been assessed and found to be in accordance with the requirements of the quality standards and scope of supply detailed below

QUALITY STANDARDS:
KS A 9001 : 1998 ISO 9001 : 1994 EN ISO 9001 : 1994

SCOPE OF SUPPLY:
Design, Development, Production and Servicing of Tube and Pipe Fittings, Instrument Valves, Manifold Valves, Ball Valves, Flanges, Fasteners, Tube Clamps

Subject to the continued satisfactory operation of the supplier's Quality Management System, this Certificate is valid for a period of three years from:
October 31, 1998
For Small & Medium Industry Certification Center Co., LTD

Re-issue Date : 01/31/2000
Issue Date : 10 / 31 / 1998
Kim yung wha
SMICC

(SMICC 40-43, REV.1)

Introduction

Dk-Lok Tube Fittings have been designed specifically for the many demanding applications chemical, petroleum, power generating, pulp, paper and various types of manufacturing industries. They provide a highly reliable, leakproof and torque free seal on all tubing connections.

Dk-Lok Tube Fittings are commonly used on instrumentation, process and control systems or any other application where a high quality tube fitting is required

Construction of Dk-Lok Fittings

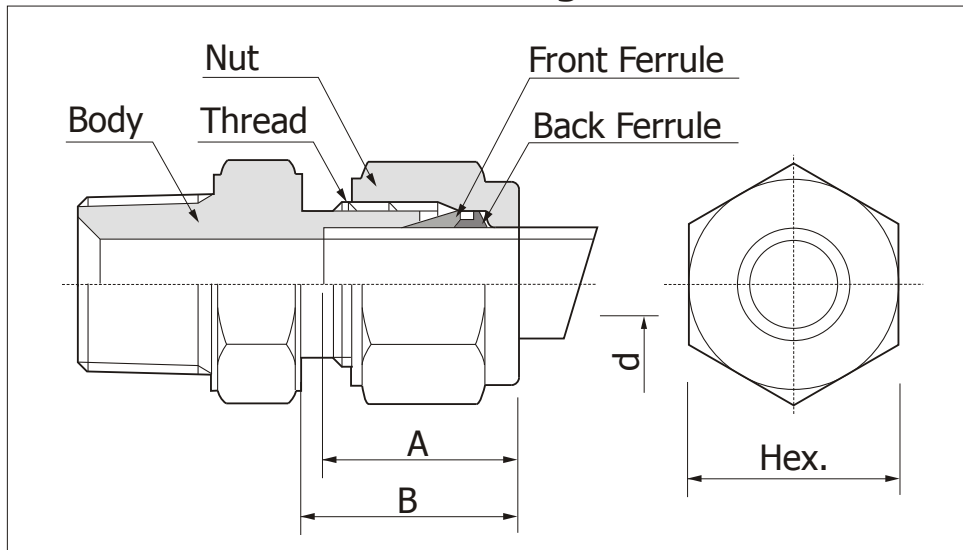

Dk-Lok Fractional Tube End Dimensions

Unit: mm

Size No.	Tube O.D.	Dk-Lok Thread	A	B	d	Hex.
2	1/8	5/16-20UN	12.70	15.24	2.28	11.10
3	3/16	3/8-20UN	13.70	16.00	3.04	12.70
4	1/4	7/16-20UNF	15.24	17.78	4.80	14.20
5	5/16	1/2-20UNF	16.25	18.54	6.35	15.80
6	3/8	9/16-20UN	16.76	19.30	7.10	17.40
8	1/2	3/4-20UNEF	22.86	21.84	10.40	22.20
10	5/8	7/8-20UNEF	24.38	21.84	12.70	25.40
12	3/4	1-20UNEF	24.38	21.84	15.70	28.60
14	7/8	1-1/8-20UN	25.90	21.84	18.20	31.80
16	1	1-5/16-20UN	31.24	26.41	22.40	38.10

DK-Lok Metric Tube End Dimension

Unit: mm

Size No.	Tube O.D.	Dk-Lok Thread	A	B	d	Hex.
3M	3mm	5/16-20UN	12.9	15.3	2.4	12.0
4M	4mm	3/8-20UN	13.7	16.1	2.4	12.0
6M	6mm	7/16-20UNF	15.3	17.7	4.8	14.0
8M	8mm	1/2-20UNF	16.2	18.6	6.4	16.0
10M	10mm	5/8-20UN	17.2	19.5	7.9	19.0
12M	12mm	3/4-20UNEF	22.8	22.0	9.5	22.0
15M	15mm	7/8-20UNEF	24.4	22.0	11.9	25.0
16M	16mm	7/8-20UNEF	24.4	22.0	12.7	25.0
18M	18mm	1-20UNEF	24.4	22.0	15.1	30.0
20M	20mm	1-1/8-20UN	26.0	22.0	15.9	32.0
22M	22mm	1-1/8-20UN	26.0	22.0	18.3	32.0
25M	25mm	1-5/16-20UN	31.3	26.5	21.8	38.0

Typical Raw Material List

Fitting Material	Bar Stock	Forging	Tubing
Stainless Steel Type 316	ASTM A479 ASTM A276 JIS G4303	ASTM A182 F316 JIS G3214	ASTM A269 ASTM A213 ASTM A249
Brass	ASTM B16 Alloy 360 ASTM B453 Alloy 345 JIS H3250 Alloy C3604	ASTM B283 Alloy 377 JIS H3250 Alloy C3771	ASTM B68 ASTM B75 ASTM B88 DIN 1786
Carbon Steel	JIS G4051 S20C-S48C	JIS G4051 S20C-S48C	ASTM A161 ASTM A179 DIN 2391
Alloy 400	ASTM B164	ASTM B164	ASTM B165

Standard of Quality for Dk-Lok Fittings

The Dk-Lok body, nut, back ferrule and front ferrule are manufactured under very close tolerance control and monitored through Statistic Process Control and are Heat-Code Traceable.

The twin ferrule design performs leak proof sealing with all assembly and reassembly motion being transmitted axially through the tubing. This results in no radial movement of the tubing upon assembly and reassembly. Therefore, the tubing is not stressed and the mechanical integrity is maintained. This is the result of close tolerance control in machining, surface smoothness and hardness of each and every part of the Dk-Lok tube fittings. Through this swaging action, the Dk-Lok fitting becomes integrated mechanically with the tubing connected.

Dk-Lok fittings are available in Stainless Steel, Brass and Carbon Steel as standard materials, and can be manufactured from various materials upon request. Dk-Lok fittings are tested according to JIS B2351 & BS4368 standards.

Tubing & Tube Fitting Benefits

Tubing has many benefits over piping. Since tubing is able to be bent, this allows lower pressure drop due to fewer connections. This in turn reduces costs because of less fabricating manpower. Dk-Lok connections do not require threading or welding, and are assembled by standard wrench make-up. This results in less assembly and maintenance costs.

Tubing Selection

For safe, reliable and leak-free seals, tubing should be considered as a fitting component. Quality Dk-Lok fittings provide the best performance when good tubing is used. Care should be taken and general rules followed to have good tubing connections.

Tubing - General Rules

1. For leak-free sealing, the tubing surface is very important. The Tubing must have a good surface free from scratches, draw mark, flat spots or dirt.
2. In case of welded tubing, it should not have a visible poor bead on its outside diameter.
3. Using like tubing and fitting material is essential for the same thermal compatibility and corrosion resistance. The tubing material should be compatible with the process fluid, temperature and environment.
4. Tubing must be softer than fitting material. When tubing and fittings are made of the same material, the metal tubing must be fully annealed.
5. Tubing hardness must be selected according to the information in the table 2 to 8 .
6. Do not select a too thin or thick wall. A too thin wall may collapse and a too thick wall may not properly be deformed by the ferrule action. The wall thickness selection should be based on the applicable pressure, temperature, shock and vibration.
7. Tubing with oval or out-of-roundness appearance may not fit into the fitting. Do not force the tubing into the fitting, it may damage the fitting sealing system of the nut, ferrules, or the body.

Purchasing the tubing based on the industrial standards such as ASTM or other equivalent specifications doesn't mean that you have the right tubing when we see other variables.

See variables below for taking care of your tubing

- | | |
|---------------------------------|---------------------|
| 1. Material Grade | 2. Weld or Seamless |
| 3. O.D. and Tolerance | |
| 4. Wall thickness and Tolerance | |
| 5. Hardness | 6. Ovality (Shape) |
| 7. Concentricity | 8. Surface finish |

Tube cutting and de-burr both ends

Use tube cutter for straight cutting of tubing and clean metal chips from both I.D. and O.D. of the tube with deburring tool. Hacksaw can be used for cutting improper size by tube cutter and hacksaw blades should have at least 32 teeth per inch.

Tube bending

Bendability is one of tubing benefits against piping this causes fewer connections therefore fewer leaks potentiality of the system.

Proper tube bending practices ensure against potential leaks or hazards.

- * Bend prior to installing fittings.
- * Use tube bender, Do not bend a tube placed in the fitting.
- * Do not bend close to fitting, allow a certain straight distance from fitting to the starting point of tube bend. For further details, see page 58.

Tubing Temperature Ratings

The Maximum and Minimum operating temperatures for various tubing material

Tubing Material	Temperature Range
Stainless Steel 316	-321F to 1200F (-196°C to 469°C)
Carbon Steel	-65F to 799F (-53°C to 426°C)
Copper	-40F to 400F (-40°C to 205°C)
Alloy 400	-324F to 800F (-198°C to 427°C)
Alloy C276	-320F to 1000F (-195°C to 537°C)
Alloy 600	-205F to 1200F (-130°C to 648°C)
Titanium	-320F to 600F (-195°C to 315°C)
Teflon	0F to 150F (-17°C to 65°C)

Temperature De-rating Factors

The allowable working pressure is determined by various temperatures.

To determine the working pressure at the specific temperatures, multiply the working pressure at ambient temperature shown in table 2~8 by the factor shown in table 1.

Example : Tube SS316 1/2" O.D.x0.065" at 700 F.

$$5100\text{psi} \times 0.82 = 4182 \text{ psi.}$$

Therefore 4182 psi is the maximum allowable working pressure of SS316 1/2" O.D. X 0.065" wall tubing.

Table 1. Temperature De-rating Factors

Temp. °F (°C)	Stainless Steel ASTM A269		C. Steel ASTM	Copper ASTM	Alloy 400
	304	316	A179	B75	
100 (38)	1.00	1.00	1.00	1.00	1.00
200 (93)	1.00	1.00	0.96	0.80	0.88
300 (149)	1.00	1.00	0.90	0.78	0.82
400 (204)	0.94	0.97	0.86	0.50	0.79
500 (260)	0.88	0.90	0.82	0.13	0.79
600 (316)	0.82	0.85	0.77	-	0.79
700 (371)	0.80	0.82	0.73	-	0.79
800 (427)	0.76	0.80	0.59	-	0.76
900 (482)	0.73	0.78	-	-	-
1000 (538)	0.69	0.77	-	-	-
1200 (649)	0.30	0.37	-	-	-

Allowable working temperature

When Elastomer seal is used in the fitting, care must be taken for allowable working temperature. See working temperature below.

Elastomer seal material	Working Temperature
NBR (e. g. Perbunan [®])	-40 C to 110°C (-40°F to 230 F)
FKM (e. g. Viton [®])	-28 C to 204°C (-20°F to 400 F)
PTFE (e. g. Teflon [®])	-60C to 240°C (-76 F to 464 F)

Stainless Steel Tubing

Fully annealed 304 or 316 seamless to ASTM A269 or equivalent, suitable for bending and flaring.
Hardness : Rb 80 or less

Table 2. For Seamless Stainless Steel Fractional Tubing

Tube O.D. (Inches)	Tube Wall Thickness in Inches														
	0.012	0.014	0.016	0.020	0.028	0.035	0.049	0.065	0.083	0.095	0.109	0.120	0.134	0.156	0.188
1/16"	6,800	8,100	9,400	12,000											
1/8"					8,500	10,900									
3/16"					5,400	7,000	10,200								
1/4"					4,000	5,100	7,500	10,200							
5/16"						4,000	5,800	8,000							
3/8"						3,300	4,800	6,500							
1/2"							2,400	3,500	4,700	6,200					
5/8"								2,900	4,000	5,200	6,000				
3/4"								2,400	3,300	4,200	4,900	5,800			
7/8"								2,000	2,800	3,600	4,200	4,800			
1"									2,400	3,100	3,600	4,200	4,700		
1-1/4"										2,400	2,800	3,300	3,600	4,100	4,900
1-1/2"											2,300	2,700	3,000	3,400	4,000
2"												2,000	2,200	2,500	2,900

Table 3. For Seamless Stainless Steel Metric Tubing

Tube O.D. (mm)	Tube Wall Thickness in Millimeters												
	0.8	1.0	1.2	1.5	1.8	2.0	2.2	2.5	2.8	3.0	3.5	4.0	4.5
3	710												
6	330	420	520	670									
8		310	380	490									
10		240	300	380									
12		200	240	310	380	430							
14		180	220	280	340	390	430						
15		170	200	260	320	360	400						
16			190	240	300	330	370						
18			170	210	260	290	320	370					
20			150	190	230	260	290	330	380				
22			130	170	210	230	260	300	300				
25				180	200	230	260	290	320				
28					180	200	230	260	280	330			
30					170	190	210	240	260	310			
32					160	170	200	230	240	290	330		
38						140	170	190	200	240	280	310	

- Working pressures are based on allowable stress value of 20,000PSI (137,800kPa=1,378bar) as specified by ASME B31 .3-1999 over the temperature range of -29 °C to 37 °C (-20 °F to 100 °F).
- Safety Factor = 3.75:1, considering ultimate tensile strength 75,000PSI (516,700kPa=5,167bar)
- Pressure calculations are based on maximum O.D. and minimum wall thickness and no allowance is made for corrosion and erosion. e.g. ASTM A269 1/2 OD x 0.035:
OD tolerance ±0.005", W.T± 10%. Calculations are based on 0.505"OD x 0.0315" W.T.
- To determine Bar, multiply PSIG by 0.0689. To determine kPa, multiply PSIG by 6.89,
- To convert bar to PSIG, multiply bar by 14.51 ■ For working pressure per ASME B31.1, multiply value by 0.94

Welded Stainless Steel Tubing

Based on ASME B31.3 _1999 for weld integrity a de-rating factor must be applied to welded tubing.
For double butt seam tubing multiply by 0.85 and for single butt seam tubing multiply by 0.80.

Copper Tubing

Soft annealed seamless to ASTM B75 or equivalent.
Hardness : Rb 60 or less

Table 4. For Seamless Copper Fractional Tubing

Tube O.D. (Inches)	Tube Wall Thickness in Inches									
	0.010	0.012	0.028	0.035	0.049	0.065	0.083	0.095	0.109	0.120
1/8"			2,700	3,600						
3/16"			1,800	2,300	3,400					
1/4"			1,300	1,600	2,500	3,500				
5/16"				1,300	1,900	2,700				
3/8"				1,000	1,600	2,200				
1/2"				800	1,100	1,600	2,100			
5/8"					900	1,200	1,600	1,900		
3/4"					700	1,000	1,300	1,500	1,800	
7/8"					600	800	1,100	1,300	1,500	
1"					500	700	900	1,100	1,300	1,500

Table 5. For Seamless Copper Metric Tubing

Tube O.D. (mm)	Tube Wall Thickness in Millimeters										
	0.7	0.8	1.0	1.2	1.5	1.6	1.8	2.0	2.2	2.5	3.0
3	225	260									
4	165	191	244	295							
6		122	157	192	245	263					
8		89	114	140	179	193					
10		70	89	109	140	150	172	193			
12		58	73	89	114	123	140	158			
14			62	76	96	103	118	133	148	171	209
16			54	66	83	89	102	114	127	147	180
18			48	58	74	79	90	101	112	129	159
22			39	47	59	64	72	81	90	103	126
25			34	41	52	56	63	71	78	90	110

- Working pressures are based on allowable stress value of 6,000PSI (413 bar=41,300kPa) as specified by ASME B31.3-1999 over the temperature range of -29 °C to 37 °C (-20 °F to 100 °F).
- Safety Factor = 5:1, considering ultimate tensile strength 30,000PSI (2067 bar=206,700kPa)
- Pressure calculations are based on maximum O.D. and minimum wall thickness and no allowance is made for corrosion and erosion
- For working pressure per ASME B31.1, multiply value by 0.94

Carbon Steel Tubeing

Soft annealed seamless to ASTM A179 or equivalent, free from scratches, suitable for bending & flaring.
Hardness: Rb72 or less.

Table 6. For Seamless Carbon Steel Fractional Tubing

Tube O.D. (Inches)	Tube Wall Thickness in Inches												
	0.028	0.035	0.049	0.065	0.083	0.095	0.109	0.120	0.134	0.148	0.165	0.180	0.220
1/8"	8,000	10,200											
3/16"	5,100	6,600	9,600										
1/4"	3,700	3,700	7,000	9,600									
5/16"		3,800	5,500	7,600									
3/8"		3,100	4,500	6,200									
1/2"		2,300	3,300	4,500	5,900								
5/8"		1,800	2,600	3,500	4,600	5,300							
3/4"			2,100	2,900	3,700	4,300	5,100						
7/8"			1,800	2,400	3,200	3,700	4,300						
1"			1,500	2,100	2,700	3,200	3,700	4,100					
1-1/4"				1,600	2,100	2,500	2,900	3,200	3,600	4,000	4,600	5,000	
1-1/2"					1,800	2,000	2,400	2,600	3,000	3,300	3,700	4,100	5,100
2"						1,500	1,700	1,900	2,200	2,400	2,700	3,000	3,700

Working Pressure in Psig

Table 7. For Seamless Carbon Steel Metric Tubing

Tube O.D. (mm)	Tube Wall Thickness in Millimeters												
	0.8	1.0	1.2	1.5	1.8	2.0	2.2	2.5	2.8	3.0	3.5	4.0	4.5
3	670	830											
6	310	400	490	630									
8		290	360	460									
10		230	280	360									
12		190	230	290	360	410	450						
14		160	190	250	300	340	380						
15		150	180	230	280	320	350						
16			170	210	260	290	330	380					
18			150	190	230	260	290	330					
20			130	170	200	230	250	290	330				
22			120	150	180	210	230	260	300				
25					160	180	200	230	260	280			
28						160	180	200	230	250	290		
30						150	160	190	210	230	270		
32						140	150	170	200	210	250	290	
38							130	140	160	180	210	240	280

Working Pressure in Bar

- Working pressures are based on allowable stress value of 15,700PSI (1082 bar=108,200kPa) as specified by ASME B31.3-1999 over the temperature range of -29 °C to 37 °C (-20 °F to 100 °F).
- Safety Factor = 3.75:1, considering ultimate tensile strength 47,000PSI (3237 bar=323,700kPa).
- Pressure calculations are based on maximum O.D. and minimum wall thickness and no allowance is made for corrosion and erosion.
- For working pressure per ASME B31.1, multiply value by 0.94

Alloy 400 Tubing

Fully annealed seamless Alloy 400 tubing to ASTM B165 or equivalent.
Hardness: Rb75 or less

Table 8. For Seamless Alloy 400 Fractional tubing

Tube O.D. (Inches)	Tube Wall Thickness in Inches							
	0.028	0.035	0.049	0.065	0.083	0.095	0.109	0.120
1/8"	7,900	10,200						
1/4"	3,700	4,800	7,000	9,600				
3/8"		3,100	4,400	6,100				
1/2"		2,300	3,300	4,400				
3/4"			2,200	3,000	4,600	4,600		
1"				2,200	2,900	3,400	3,900	4,300

- Working pressures are based on allowable stress value of 18,700PSI (128,800kPa=1288bar) as specified by ASME B31.3-1999 over the temperature range of -29 °C to 37 °C (-20 °F to 100 °F).
- Safety Factor = 3.75:1, considering ultimate tensile strength 70,000PSI (482,300kPa=4,823bar)
- Pressure calculations are based on maximum O.D. and minimum wall thickness and no allowance is made for corrosion and erosion.
- For working pressure per ASME B31.1, multiply value by 0.94

Special Alloy Tubing

When Special Alloy Tubing is Selected, we recommend : Fully Annealed Seamless (or Welded and Cold-draw, where permitted) Alloy Tubing to the ASTM specification as shown below. Tubing should be free of scratches for bending or flaring.

DK-LOK material Designator	Tube Material	ASTM Number	Tubing	
			Type	Maximum Hardness
HC	Alloy C276	B622	Seamless	RB 90
IN	Alloy 600	B167	Seamless	RB 90
Ti	Titanium - Grade 2	B338	Seamless or Welded	RB 90

Pressure Rating Equivalents :

- | | |
|---------------------------------|--|
| 1) 1 bar = 100 kPa = 14.51 psi | 2) 1 kPa = 0.01 bar = 0.1451 psi |
| 3) 1 psi = 0.069 bar = 6.89 kPa | 4) 1 kg/cm ² = 0.98 bar = 14.22 psi |

Tubing for Gas application

Dk-Lok tube fittings are designed for a wide range of leak-free application including gas leak proof and vacuum service. Gases can escape even the most minute leakpath due to their small molecules, Tube must therefore be carefully handled not to get scratched.

Use heavier wall tubing for gas service. Heavy wall tubing resists ferrule action by coining out minor defects of the tube surface and thin wall tubes may collapse with little resistance to ferrule action.

For Gas service, use the tubing of the un-shadowed section in table 5 - 8.

Cryogenic Service

Dk-Lok Fittings in S316 Stainless Steel provide highly reliable performance from Cryogenic Temperatures to High Temperature Levels.

S316 Stainless Steel Temperature Rating : -321 °F to 1200 °F (-196 °C to 649 °C)

Cryogenic Temperature are considered to be Temperatures Below : -100 F ° (-73 °C)

Pipe Thread

Many Dk-Lok tube fittings have a male or female pipe end. These ends sometimes have a lower pressure rating than the pressure rating of the tube fitting end.

Table 9. Pipe End Pressure Rating

Size Designator	ISO/NPT Pipe Size	Stainless Steel 316				Brass				Carbon Steel			
		Male		Female		Male		Female		Male		Female	
		psig	bar	psig	bar	psig	bar	psig	bar	psig	bar	psig	bar
1	1/16	14,000	758	6,600	455	7,400	510	3,300	227	14,000	965	6,600	455
2	1/8	10,000	689	6,400	441	5,000	345	3,200	221	10,000	689	6,400	441
4	1/4	8,300	572	6,500	448	4,100	282	3,200	220	8,300	572	6,500	448
6	3/8	10,000	689	5,200	358	5,300	365	2,600	179	10,000	689	5,200	358
8	1/2	7,800	537	4,800	331	3,900	269	2,400	165	7,800	537	4,800	331
12	3/4	7,500	517	4,600	317	3,700	255	2,300	159	7,500	517	4,600	317
16	1	5,300	365	4,400	303	2,600	179	2,200	152	5,300	365	4,400	303
20	1-1/4	6,200	427	5,000	345	3,100	214	2,500	172	6,200	427	5,000	345
24	1-1/2	5,100	351	4,500	310	2,500	172	2,200	152	5,100	351	4,500	310
32	2	4,000	276	3,900	269	2,000	138	1,900	131	4,000	276	3,900	269

- The ratings shown above are based on ASME B31.3-1999
- Female pipe ends have lower ratings than male pipe in a given size due to the inner and outer diameters of female threads being larger than those of male pipe ends.
- The ratings shown above are reference only.

Pipe Thread Sealant

Pipe thread sealant is essential to ensure leak-free seal. Since the Teflon tape is commonly used, we provide information of recommended tape width, as well as the numbers of thread to be wrapped. The TeflonTM tape fills the voids between threads and prevents galling on pipe threads. The sealant usually contains a lubricant.

Table 10.

Unit : Inches

Nominal Pipe Size	Recommended Tape Width	Effective Thread Length (External) L _{有效}	Approx.# of Thread
1/8	1/8 - 1/4	0.2639	7
1/4	1/4	0.4018	7-1/4
3/8	1/4	0.4075	7-1/3
1/2	1/4 - 1/2	0.5337	7-1/2
3/4	1/4 - 1/2	0.5457	7-2/3
1	1/4 - 1/2	0.6828	8

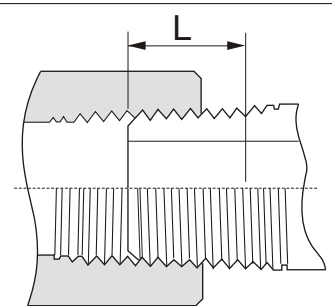

ASME B1.20.1-NPT

- Note: 1. Wrap TeflonTM Tape clockwise from first thread. Do not overhang the first thread, as the tape may get into the fluid system.
2. TeflonTM tape has a temperature limit of 230°C (450 °F).

Note : The information shown in table 1-10 are not for design purpose, but for reference only. The accuracy of information is not the liability of our company.

Ordering Information

Dk-Lok tube fittings are ordered by the part number which is constructed as per SAE recommended practice.

1. Tube to Pipe ends

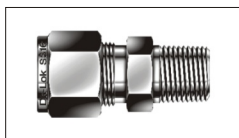

Example : DMC 4-4N-B
Dk-Lok Male Connector.
Tube O.D. 1/4 " x 1/4" Male NPT, Brass.

D MC 4 - 4 N - B
① ② ③ ④ ⑤ ⑥

- ① Dk-Lok designated as "D" ② Name of Fittings : See fitting type designator ③ Tube O.D.: See tube O.D.designator
- ④ Pipe thread size : See pipe thread designator ⑤ Pipe thread Symbols : See pipe thread symbol
- ⑥ Material : See fitting material designator

2. Tube to Tube ends

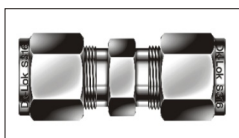

Example : DU-8-S
Dk-Lok Union
Tube O.D. 1/2 " material S316

D U - 8 - S
① ② ③ ④ ⑤ ⑥

3. Tee & Cross

Tees are described by first the run (1 and 2) and next the branch (3).

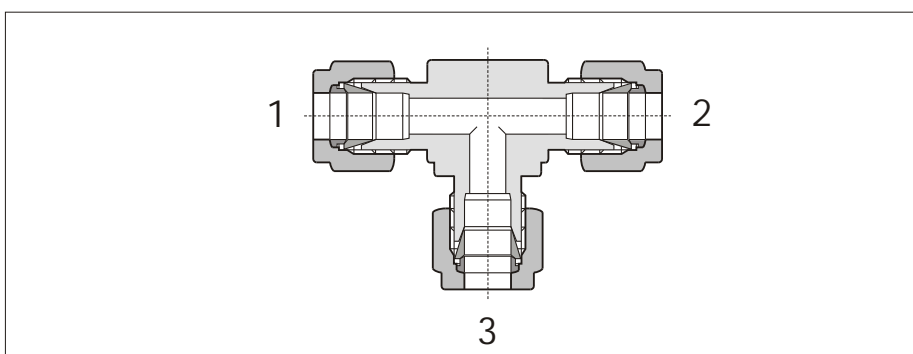

Crosses are described by first the run (1 and 2) and next the branch (3 and 4).

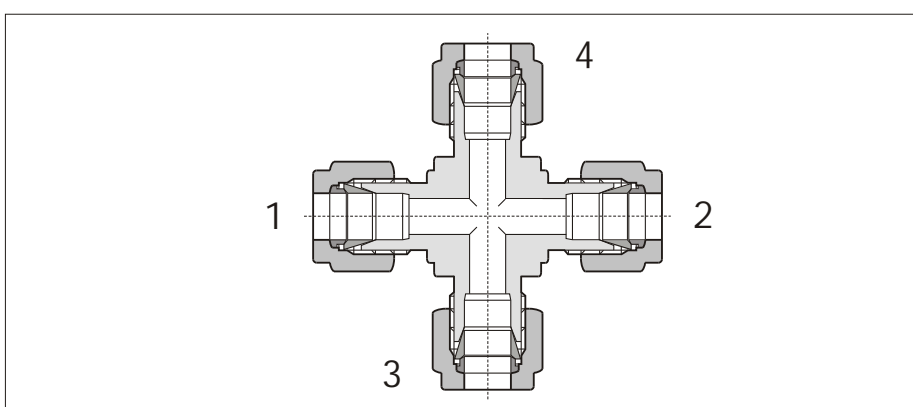

Stepped Shoulder of Dk-Lok Metric Tube Fittings

Metric Dk-Lok is obviously different from Fractional with the stepped shoulders machined on Nut and fitting body.

Metric DK-Lok Tube Fittings

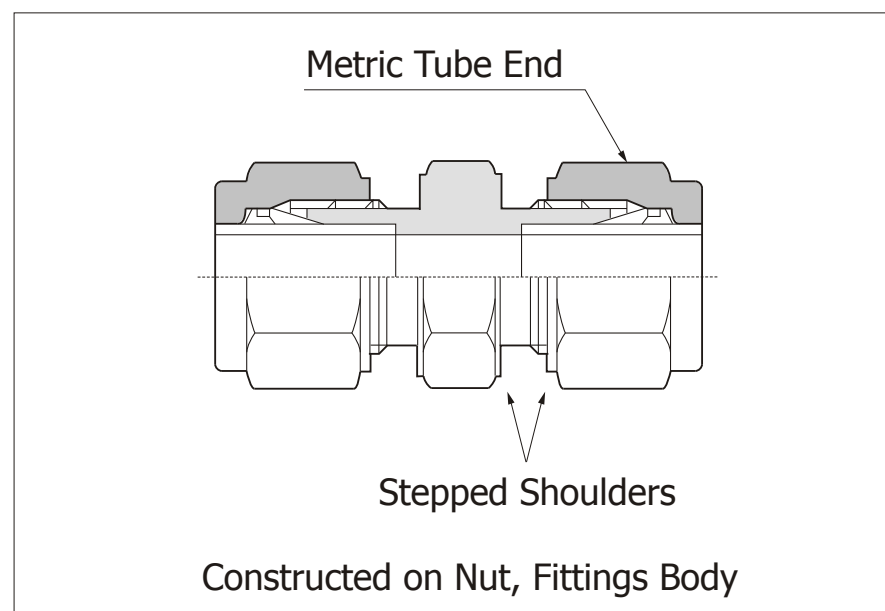

② Fitting type Designator

Identifier	Description
DU	Union
DL	Union Elbow
DUR	Reducing Union
DT	Union Tee
DX	Union Cross
DUB	Bulkhead Union
DMCT	Thermocouple Connector
DMC-N	Male Connector
DMC-R	Male Connector
DMC-G	Male Connector for Bonded Seal
DOM	Male Connector for Metal Gasket
DMCB	Bulkhead Male Connector
DLBM	45° Male Elbow
DLM	Male Elbow
DTRM	Male Run Tee
DTBM	Male Branch Tee
DCF	Female Connector
DCG	Gauge Connector
DCBF	Bulkhead Female Connector
DLF	Female Elbow
DTRF	Female Run Tee
DTBF	Female Branch Tee
DR	Reducer
DAB	Bulkhead Adapter
DAM	Male Adapter

Identifier	Description
DAF	Female Adapter
DCP	Port Connector
DCRP	Reducing Port Connector
DUA	AN Union
DUBA	AN Bulkhead Union
DAA	AN Adapter
DMCS	SAE Male Connector
DLS	SAE Male Elbow
DLBS	45° Male Elbow
DTRS	SAE Male Run Tee
DTBS	SAE Male Branch Tee
DCOS	O-Seal Straight Thread Connector
DCOP	O-Seal Pipe Thread Connector
DCW	Male Pipe Weld Connector
DLW	Male Pipe Weld Elbow
DCSW	Tube Socket Weld Connector
DLSW	Tube Socket Weld Elbow
DP	Plug
DC	Cap
DI	Tube Insert
DN	Nut
DFF	Front Ferrule
DFB	Back Ferrule
DFS	Ferrule Set
DHS-1A	Dk-Lok Hydraulic Swaging Unit

③ Tube O.D. Designator

Inch O.D.	1/16	1/8	3/16	1/4	5/16	3/8	1/2	5/8	3/4	7/8	1	1-1/4	1-1/2	2
Identifier	1	2	3	4	5	6	8	10	12	14	16	20	24	32
Metric O.D.	2mm	3mm	4mm	6mm	8mm	10mm	12mm	16mm	20mm	22mm	25mm	28mm	32mm	38mm
Identifier	2M	3M	4M	6M	8M	10M	12M	16M	20M	22M	25M	28M	32M	38M

④ Pipe Thread Size Designator

Nom. Size	1/8"	1/4"	3/8"	1/2"	3/4"	1"	1-1/4"	1-1/2"	2"
Identifier	2	4	6	8	12	16	20	24	32

⑥ Fitting Material Designator

Material	SS 316	SS 316L	SS 304	C.Steel	Brass	Alloy400
Identifier	S	L	4	C	B	M

⑤ Pipe Thread Symbol

Type	Symbol	Specification
Taper Threads	R	ISO 7/1, BS21(BSPT), JIS B 0203(PT), DIN2999
	N	ANSI B1.20.1 (NPT)
Parallel Threads	G	ISO228/1, BS 2779(BSPP), JIS B0202(PF)
	U	American Standard Unified Screw Threads

Introducing the Z-Series Single Ferrule Technology from *Dk-Lok*[®]

Dk-Lok Z-Series Fittings Ordering

Using cutting-edge engineering, Dk-Lok has designed and manufactured Z-Series Single Ferrule Fittings to the highest quality standards.

Leak-Free Z-Series Nuts and Ferrules are designed to use with the Dk-Lok Tube Fitting Body.

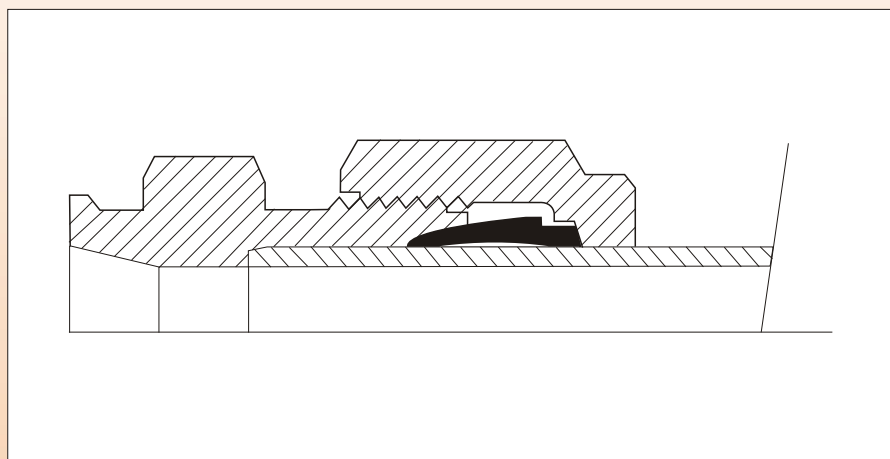

Features include:

- Single Ferrule Design
- Corrosion Resistance Ferrule
- Fine Molybdenum Disulfide (MoS₂) coated Nut to prevent galling and additional thread lubricant
- Positive leak-free seal
- Standard S316 and Brass Materials

Materials, Pressure Ratings, Installation and Tubing Selection.

Materials of the Dk-Lok Z-Series Nut and Ferrule, Pressure ratings (when connected with Tubing), Installation and Tubing selections are identical to those of Dk-Lok Tube Fittings. Please refer to a Dk-Lok catalog for additional information

DFZ-Ferrule

Ferrule	
Part No.	Tube O.D.
DFZ-4	1/4
DFZ-6	3/8
DFZ-8	1/2
DFZ-12	3/4
DFZ-16	1

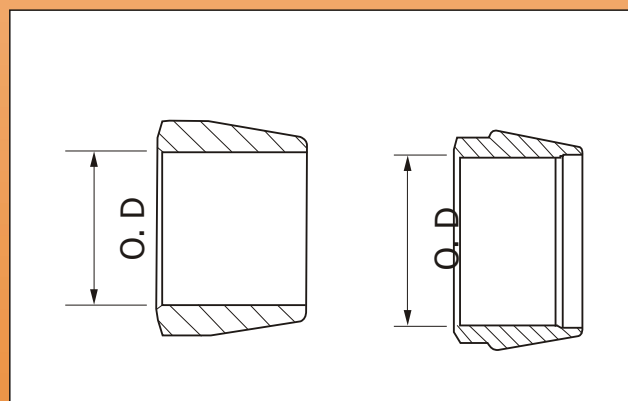

DNZ-Nut



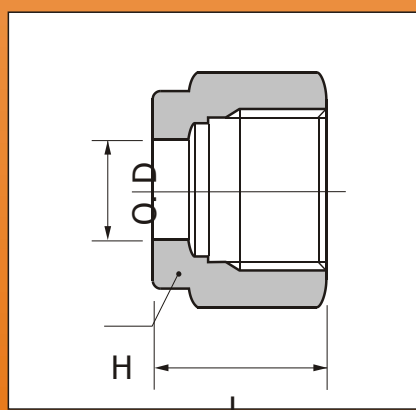



Nut			
Part No.	Tube O.D.	Hex H	L inch
DNZ-4	1/4	9/16	0.50
DNZ-6	3/8	11/16	0.56
DNZ-8	1/2	7/8	0.69
DNZ-12	3/4	1-1/8	0.69
DNZ-16	1	1-1/2	0.81









Identifier	Description
DUZ	Union
DLZ	Union Elbow
DURZ	Reducing Union
DTZ	Union Tee
DXZ	Union Cross
DUBZ	Bulkhead Union
DMCZ-N	Male Connector
DMCZ-R	Male Connector
DMCTZ	Thermocouple Connector
DMCZ- G	Male Connector for Bonded Seal
DOMZ	Male Connector for Metal Gasket
DMCBZ	Bulkhead Male Connector
DLBMZ	45° Male Elbow
DLMZ	Male Elbow
DTRMZ	Male Run Tee
DTBMZ	Male Branch Tee
DCFZ	Female Connector
DCGZ	Gauge Connector
DCBFZ	Bulkhead Female Connector
DLFZ	Female Elbow
DTRFZ	Female Run Tee
DTBFZ	Female Branch Tee
DRZ	Reducer
DABZ	Bulkhead Adapter
DAMZ	Male Adapter
DAFZ	Female Adapter
DCPZ	Port Connector
DUAZ	AN Union
DUBAZ	AN Bulkhead Union
DA AZ	AN Adapter
DMCSZ	SAE Male Connector
DLSZ	Positionable SAE Male Elbow
DLBSZ	Positionable 45 ° SAE Male Elbow
DTRSZ	Positionable SAE Male Run Tee
DTBSZ	Positionable SAE Male Branch Tee
DCOSZ	O -Sea Straight Thread Connector
DCOPZ	O -Sea IPipe Thread Connector
DCWZ	Male Pipe Weld Connector
DLWZ	Male Pipe Weld Elbow
DCSWZ	Tube Socket Weld Connector
DLSWZ	Tube Socket Weld Elbow
DPZ	Plug
DCZ	Cap
DNZ	Nut
DFZ	Ferrule

All the Assembly Dimensions are Identical to those of Dk-Lok fittings. For Additional Details, Please Refer to the Dimensional Table of each Fitting.

Tube to Tube Union

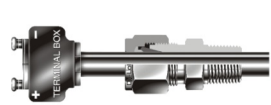

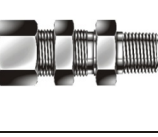
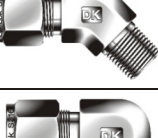
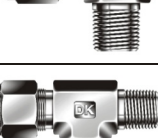
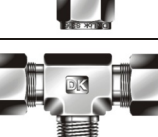

Union DU		13
Union Elbow DL		14
Reducing Union DUR		15,16
Union Tee DT		17
Union Cross DX		18
Bulkhead Union DUB		19

Tube to Male Pipe





Male Connector DMC -N		20
Male Connector DMC -R		21
Thermocouple Connector DMCT		21
Male Connector for Bonded Seal DMC - G		22
Male Connector for Metal Gasket DOM		24,25
Vent Protector DMD		25
Bulkhead Male Connector DMCB		26
45° Male Elbow DLBM		26
Male Elbow DLM		27,28
Male Run Tee DTRM		29,30
Male Branch Tee DTBM		31,32

Tube to Female Pipe

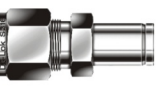
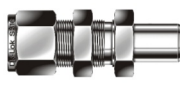

Female Connector DCF		33,34
--------------------------------	---	-------

Gauge Connector DCG		35
Bulkhead Female Connector DCBF		35
Female Elbow DLF		36
Female Run Tee DTRF		37
Female Branch Tee DTBF		38



Stub Tube Connector

Reducer DR		39,40
Bulkhead Adapter DAB		41
Male Adapter DAM		41,42
Female Adapter DAF		43
Port Connector DCP		44
Reducing Port Connector DCRP		44

Tube to AN Tube

AN Union DUA		45
AN Bulkhead Union DUBA		45
AN Adapter DAA		45

Tube to SAE O- Ring Seal



SAE Male Connector DMCS		47
Positionable SAE Male Elbow DLS		47
Positionable 45° SAE Male Elbow DLBS		48

Positionable SAE Male Run Tee DTRS		48
Positionable SAE Male Branch Tee DTBS		48
O -Seal Straight Thread Connector DCOS		50
O -Seal Pipe Thread Connector DCOP		50







Tube to Weld End

Male Pipe Weld Connector DCW		51
Male Pipe Weld Elbow DLW		52
Tube Socket Weld Connector DCSW		52
Tube Socket Weld Elbow DLSW		52

Plug and Cap

Plug DP		53
Cap DC		53

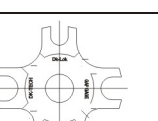
Spare Parts

Tube Insert DI		54
Nut DN		54
Front Ferrule DFF		55
Back Ferrule DFB		55
Ferrule Set DFS		55
Gap Gauge DIG		55
Swaging Unit DHS-1A		56

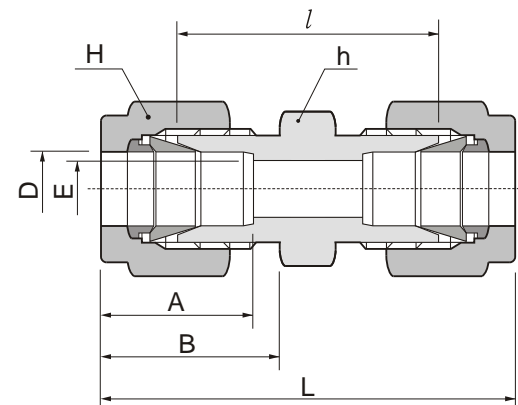
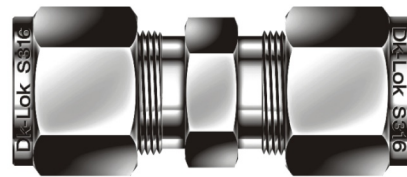

Connects fractional tube

Part No.	Tube O.D.		E Min.	Width across flat				A	B	l	L
	D			h		H					
	in	mm		in	mm	in	mm				
DU-1	1/16	1.59	1.27	5/16	7.93	5/16	7.93	8.63	10.92	17.50	25.15
DU-2	1/8	3.17	2.28	7/16	11.11	7/16	11.11	12.70	15.24	22.35	35.56
DU-3	3/16	4.76	3.04	7/16	11.11	1/2	12.70	13.71	16.00	24.13	37.33
DU-4	1/4	6.35	4.82	1/2	12.70	9/16	14.28	15.24	17.78	26.16	40.89
DU-5	5/16	7.93	6.35	9/16	14.28	5/8	15.87	16.25	18.54	28.19	42.92
DU-6	3/8	9.52	7.11	5/8	15.87	11/16	17.46	16.76	19.30	30.22	44.95
DU-8	1/2	12.70	10.41	13/16	20.64	7/8	22.22	22.86	21.84	30.98	51.30
DU-10	5/8	15.87	12.70	15/16	23.81	1	25.40	24.38	21.84	31.75	52.07
DU-12	3/4	19.05	15.74	1-1/16	26.98	1-1/8	28.58	24.38	21.84	33.27	53.59
DU-14	7/8	22.22	18.28	1-3/16	30.16	1-1/4	31.75	25.90	21.84	35.05	55.37
DU-16	1	25.40	22.35	1-3/8	34.92	1-1/2	38.10	31.24	26.41	40.38	64.77
DU-20	1-1/4	31.75	27.68	1-3/4	44.45	1-7/8	47.63	41.14	38.86	48.00	92.20
DU-24	1-1/2	38.10	34.03	2-1/8	53.97	2-1/4	57.15	50.03	45.21	53.60	107.95
DU-32	2	50.80	45.97	2-3/4	69.85	3	76.20	67.56	62.73	74.70	149.35

Connects metric tube

Part No.	Tube O.D. D	E Min.	Width across flat		A	B	l	L
			h	H				
DU-2M	2	1.7	12	12	12.9	15.3	22.4	35.6
DU-3M	3	2.4	12	12	12.9	15.3	22.1	35.3
DU-4M	4	2.4	12	12	13.7	16.1	24.1	37.3
DU-6M	6	4.8	14	14	15.3	17.7	26.2	41.0
DU-8M	8	6.4	15	16	16.2	18.6	28.2	43.2
DU-10M	10	7.9	18	19	17.2	19.5	31.0	46.2
DU-12M	12	9.5	22	22	22.8	22.0	31.0	51.2
DU-15M	15	11.9	24	25	24.4	22.0	31.8	52.0
DU-16M	16	12.7	24	25	24.4	22.0	31.8	52.0
DU-18M	18	15.1	27	30	24.4	22.0	33.3	53.5
DU-20M	20	15.9	30	32	26.0	22.0	34.8	55.0
DU-22M	22	18.3	30	32	26.0	22.0	34.8	55.0
DU-25M	25	21.8	35	38	31.3	26.5	40.4	65.0
DU-28M	28	21.8	41	46	36.6	36.6	43.4	85.0
DU-32M	32	28.6	46	50	42.0	41.6	51.3	97.3
DU-38M	38	33.7	55	60	49.4	47.9	58.4	113.6

Union Elbow DL

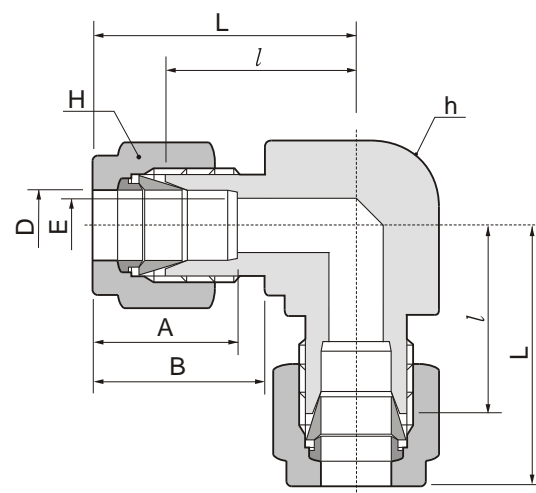

Connects fractional tube

Part No.	Tube O.D. D		E Min.	Width across flat				A	B	l	L
	in	mm		h	H	in	mm				
DL-1	1/16	1.59	1.27	3/8	9.52	5/16	7.93	8.63	10.92	14.00	17.88
DL-2	1/8	3.17	2.28	3/8	9.52	7/16	11.11	12.70	15.24	15.74	22.35
DL-3	3/16	4.76	3.04	1/2	12.70	1/2	12.70	13.71	16.00	17.78	24.38
DL-4	1/4	6.35	4.82	1/2	12.70	9/16	14.28	15.24	17.78	19.55	26.92
DL-5	5/16	7.93	6.35	9/16	14.28	5/8	15.87	16.25	18.54	21.33	28.70
DL-6	3/8	9.52	7.11	5/8	15.87	11/16	17.46	16.76	19.30	23.11	30.48
DL-8	1/2	12.70	10.41	13/16	20.64	7/8	22.22	22.86	21.84	25.90	36.06
DL-10	5/8	15.87	12.70	15/16	23.81	1	25.40	24.38	21.84	28.70	38.80
DL-12	3/4	19.05	15.74	1-1/16	26.98	1-1/8	28.58	24.38	21.84	29.71	39.87
DL-14	7/8	22.22	18.28	1-1/4	31.75	1-1/4	31.75	25.90	21.84	34.54	44.70
DL-16	1	25.40	22.35	1-27/64	36.12	1-1/2	38.10	31.24	26.41	36.83	49.02
DL-20	1-1/4	31.75	27.68	1-11/16	42.86	1-7/8	47.63	41.14	38.86	44.50	66.54
DL-24	1-1/2	38.10	34.03	2	50.80	2-1/4	57.15	50.03	45.21	50.80	77.97
DL-32	2	50.80	45.97	2-3/4	69.85	3	76.20	67.56	62.73	69.80	107.18

Connects metric tube

Part No.	Tube O.D. D	E Min.	Width across flat		A	B	l	L
			h	H				
DL-2M	2	1.7	9.5	12	12.9	15.3	15.7	22.3
DL-3M	3	2.4	9.5	12	12.9	15.3	15.7	22.3
DL-4M	4	2.4	12.7	12	13.7	16.4	18.8	25.4
DL-6M	6	4.8	12.7	14	15.3	17.7	19.6	27.0
DL-8M	8	6.4	14.3	16	16.2	18.6	21.3	28.8
DL-10M	10	7.9	17.5	19	17.2	19.5	23.9	31.5
DL-12M	12	9.5	20.6	22	22.8	22.0	25.9	36.0
DL-15M	15	11.9	25.4	25	24.4	22.0	28.7	38.8
DL-16M	16	12.7	25.4	25	24.4	22.0	28.7	38.8
DL-18M	18	15.1	27.0	30	24.4	22.0	29.7	39.8
DL-20M	20	15.9	31.8	32	26.0	22.0	32.5	42.6
DL-22M	22	18.3	31.8	32	26.0	22.0	32.5	42.6
DL-25M	25	21.8	36.0	38	31.3	26.5	36.8	49.1
DL-28M	28	21.8	41.0	46	36.6	36.6	43.2	64.0
DL-32M	32	28.6	46.0	50	42.0	41.6	49.3	72.3
DL-38M	38	33.7	55.0	60	49.4	47.9	56.4	84.0

A, B & L are approximate figures in finger-tight.

All dimensions are in millimeters unless otherwise specified and only for reference subject to change.

Reducing Union **DUR**

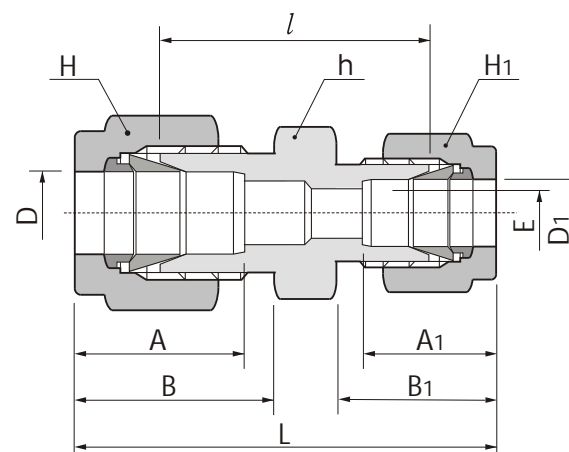
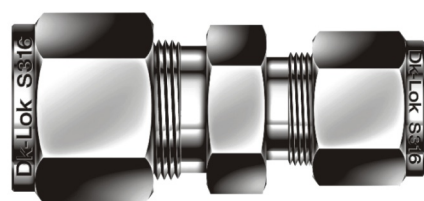

Connects fractional tube

Part No.	Tube O.D.				E Min.	Width across flat						A	A1	B	B1	l	L
	D		D1			h		H		H1							
	in	mm	in	mm		in	mm	in	mm	in	mm						
DUR-2-1	1/8	3.18	1/16	1.59	1.27	7/16	11.11	7/16	11.11	5/16	7.93	12.70	8.63	15.24	10.92	20.60	30.91
DUR-3-1	3/16	4.76	1/16	1.59	1.27	7/16	11.11	1/2	12.70	5/16	7.93	13.71	8.63	16.00	10.92	21.84	32.25
DUR-3-2	3/16	4.76	1/8	3.17	2.28	7/16	11.11	1/2	12.70	7/16	11.11	13.71	12.70	16.00	15.24	23.36	36.57
DUR-4-1	1/4	6.35	1/16	1.59	1.27	1/2	12.70	9/16	14.28	5/16	7.93	15.24	8.63	17.78	10.92	23.11	34.29
DUR-4-2	1/4	6.35	1/8	3.17	2.28	1/2	12.70	9/16	14.28	7/16	11.11	15.24	12.70	17.78	15.24	24.63	38.60
DUR-4-3	1/4	6.35	3/16	4.76	3.04	1/2	12.70	9/16	14.28	1/2	12.70	15.24	13.71	17.78	16.00	25.40	39.37
DUR-5-2	5/16	7.93	1/8	3.17	2.28	9/16	14.28	5/8	15.87	7/16	11.11	16.25	12.70	18.54	15.24	25.90	39.87
DUR-5-4	5/16	7.93	1/4	6.35	4.82	9/16	14.28	5/8	15.87	9/16	14.28	16.25	15.24	18.54	17.78	27.43	42.16
DUR-6-1	3/8	9.52	1/16	1.59	1.27	5/8	15.87	11/16	17.46	5/16	7.93	16.76	8.63	19.30	10.92	25.40	36.57
DUR-6-2	3/8	9.52	1/8	3.17	2.28	5/8	15.87	11/16	17.46	7/16	11.11	16.76	12.70	19.30	15.24	26.92	40.89
DUR-6-4	3/8	9.52	1/4	6.35	4.82	5/8	15.87	11/16	17.46	9/16	14.28	16.76	15.24	19.30	17.78	28.44	43.18
DUR-6-5	3/8	9.52	5/16	7.93	6.35	5/8	15.87	11/16	17.46	5/8	15.87	16.76	16.25	19.30	18.54	29.46	44.19
DUR-8-2	1/2	12.70	1/8	3.17	2.28	13/16	20.64	7/8	22.22	7/16	11.11	22.86	12.70	21.84	15.24	28.44	45.21
DUR-8-4	1/2	12.70	1/4	6.35	4.82	13/16	20.64	7/8	22.22	9/16	14.28	22.86	15.24	21.84	17.78	29.46	46.99
DUR-8-6	1/2	12.70	3/8	9.52	7.11	13/16	20.64	7/8	22.22	11/16	17.46	22.86	16.76	21.84	19.30	30.98	48.51
DUR-10-6	5/8	15.87	3/8	9.52	7.11	15/16	23.81	1	25.40	11/16	17.46	24.38	16.76	21.84	19.30	31.75	49.27
DUR-10-8	5/8	15.87	1/2	12.70	10.41	15/16	23.81	1	25.40	7/8	22.22	24.38	22.86	21.84	21.84	31.75	52.07
DUR-12-4	3/4	19.05	1/4	6.35	4.82	1-1/16	26.98	1-1/8	28.57	9/16	14.48	24.38	15.24	21.84	17.78	31.75	49.27
DUR-12-6	3/4	19.05	3/8	9.52	7.11	1-1/16	26.98	1-1/8	28.57	11/16	17.46	24.38	16.76	21.84	19.30	33.27	50.80
DUR-12-8	3/4	19.05	1/2	12.70	10.41	1-1/16	26.98	1-1/8	28.57	7/8	22.22	24.38	22.86	21.84	21.84	33.27	53.59
DUR-12-10	3/4	19.05	5/8	15.87	12.70	1-1/16	26.98	1-1/8	28.57	1	25.40	24.38	24.38	21.84	21.84	33.27	53.59
DUR-16-8	1	25.40	1/2	12.70	10.41	1-3/8	34.92	1-1/2	38.10	7/8	22.22	31.24	22.86	26.41	21.84	40.89	63.24
DUR-16-12	1	25.40	3/4	19.05	15.74	1-3/8	34.92	1-1/2	38.10	1-1/8	28.58	31.24	24.38	26.41	21.84	40.38	62.73

Reducing Union **DUR**

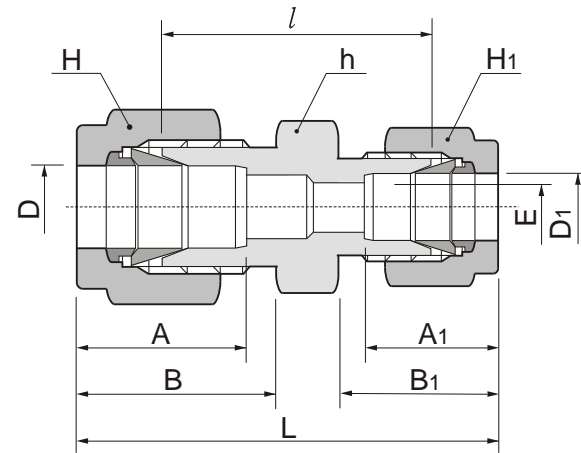
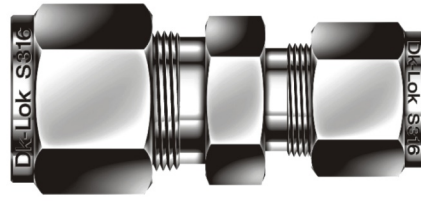

Connects metric tube

Part No.	Tube O.D.		E Min.	Width across flat			A	A1	B	B1	l	L
	D	D1		h	H	H1						
DUR 3M-2M	3	2	1.7	12	12	12	12.9	12.9	15.3	15.3	22.1	35.3
DUR 6M-2M	6	2	1.7	14	14	12	15.3	12.9	17.7	15.3	24.6	38.6
DUR 6M-3M	6	3	2.4	14	14	12	15.3	12.9	17.7	15.3	24.6	38.6
DUR 6M-4M	6	4	2.4	14	14	12	15.3	13.7	17.7	16.1	25.4	39.4
DUR 8M-6M	8	6	4.8	15	16	14	16.2	15.3	18.6	17.7	27.4	42.3
DUR 10M-6M	10	6	4.8	18	19	14	17.2	15.3	19.5	17.7	29.5	44.5
DUR 10M-8M	10	8	6.4	18	19	16	17.2	16.2	19.5	18.6	30.0	45.1
DUR 12M-6M	12	6	4.8	22	22	14	22.8	15.3	22.0	17.7	29.5	47.0
DUR 12M-8M	12	8	6.4	22	22	16	22.8	16.2	22.0	18.6	30.2	47.8
DUR 12M-10M	12	10	7.9	22	22	19	22.8	17.2	22.0	19.5	31.0	48.7
DUR 16M-10M	16	10	7.9	24	25	19	24.4	17.2	22.0	19.5	31.8	49.5
DUR 16M-12M	16	12	9.5	24	25	22	24.4	22.8	22.0	22.0	31.8	52.0
DUR 18M-12M	18	12	9.5	27	30	22	24.4	22.8	22.0	22.0	33.3	53.5
DUR 25M-18M	25	18	15.1	35	38	30	31.3	24.4	26.5	22.0	38.6	61.0
DUR 25M-20M	25	20	15.9	35	38	32	31.3	26.0	26.5	22.0	39.9	62.3

Connects metric tube to fractional tube

Part No.	Tube O.D.			E Min.	Width across flat			A	A1	B	B1	l	L
	D	D1			h	H	H1						
		in	mm										
DUR 3M-2	3	1/8	3.17	2.4	12	12	11.1	12.9	12.8	15.3	15.2	22.1	35.2
DUR 4M-2	4	1/8	3.17	2.4	12	12	11.1	13.7	12.8	16.1	15.2	23.4	36.5
DUR 4M-4	4	1/4	6.35	2.4	14	12	14.3	13.7	15.3	16.1	17.7	25.4	39.4
DUR 6M-2	6	1/8	3.17	2.4	14	14	11.1	15.3	12.8	17.7	15.2	24.6	38.5
DUR 6M-4	6	1/4	6.35	4.8	14	14	14.3	15.3	15.8	17.7	17.7	26.2	41.0
DUR 6M-5	6	5/16	7.93	4.8	14	14	15.9	15.3	16.2	17.7	18.6	27.4	42.3
DUR 8M-4	8	1/4	6.35	4.8	15	16	14.3	16.2	15.3	18.6	17.7	27.4	42.3
DUR 10M-2	10	1/8	3.17	2.4	18	19	11.1	17.2	12.8	19.5	15.2	27.7	41.8
DUR 10M-4	10	1/4	6.35	4.8	18	19	14.3	17.2	15.3	19.5	17.7	29.5	44.5
DUR 10M-5	10	5/16	7.93	6.4	18	19	15.9	17.2	16.2	19.5	18.6	30.3	45.1
DUR 10M-6	10	3/8	9.52	7.1	18	19	17.5	17.2	16.9	19.5	18.6	31.0	45.9
DUR 12M-5	12	5/16	7.93	6.4	22	22	15.9	22.8	16.2	22.0	18.6	30.2	47.8
DUR 12M-6	12	3/8	9.52	7.1	22	22	17.5	22.8	16.9	22.0	19.2	31.0	48.4
DUR 12M-8	12	1/2	12.70	9.5	22	22	22.2	22.8	22.8	22.0	22.0	31.0	51.2
DUR 15M-8	15	1/2	12.70	10.3	24	25	22.2	24.4	22.8	22.0	22.0	31.8	52.0
DUR 16M-10	16	5/8	15.87	12.7	24	25	25.4	24.4	24.4	22.0	22.0	31.8	52.0
DUR 18M-12	18	3/4	19.05	15.1	27	30	28.6	24.4	24.4	22.0	22.0	33.3	53.5
DUR 20M-12	20	3/4	19.05	15.9	30	32	28.6	26.0	24.4	22.0	22.0	34.8	54.9
DUR 20M-16	20	1	25.40	15.9	34.9	32	38.1	26.0	31.2	22.0	26.4	38.0	60.3
DUR 22M-16	22	1	25.40	18.3	34.9	32	38.1	26.0	31.2	22.0	26.4	38.2	60.3

A, B & L are approximate figures in finger-tight.

Union Tee DT

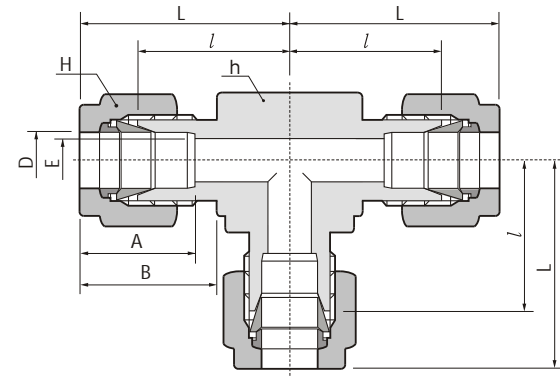
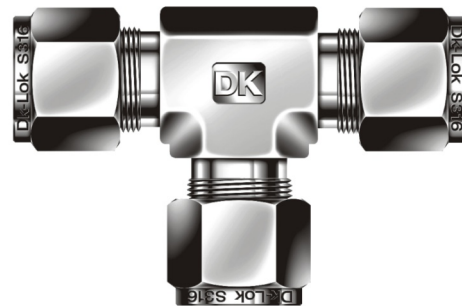

Connects fractional tube

Part No.	Tube O.D. D		E Min.	Width across flat				A	B	l	L
	in	mm		h	H	in	mm				
DT-1	1/16	1.59	1.27	3/8	9.52	5/16	7.93	8.63	10.92	14.00	17.88
DT-2	1/8	3.17	2.28	3/8	9.52	7/16	11.11	12.70	15.24	15.74	22.35
DT-3	3/16	4.76	3.04	1/2	12.70	1/2	12.70	13.71	16.00	17.78	24.38
DT-4	1/4	6.35	4.82	1/2	12.70	9/16	14.28	15.24	17.78	19.55	26.92
DT-5	5/16	7.93	6.35	9/16	14.28	5/8	15.87	16.25	18.54	21.33	28.70
DT-6	3/8	9.52	7.11	5/8	15.87	11/16	17.46	16.76	19.30	23.11	30.48
DT-8	1/2	12.70	10.41	13/16	20.64	7/8	22.22	22.86	21.84	25.90	36.06
DT-10	5/8	15.87	12.70	15/16	23.81	1	25.40	24.38	21.84	28.70	38.80
DT-12	3/4	19.05	15.74	1-1/16	26.98	1-1/8	28.58	24.38	21.84	29.71	39.87
DT-14	7/8	22.22	18.28	1-1/4	31.75	1-1/4	31.75	25.90	21.84	34.54	44.70
DT-16	1	25.40	22.35	1-27/64	36.12	1-1/2	38.10	31.24	26.41	36.83	49.02
DT-20	1-1/4	31.75	27.68	1-11/16	42.86	1-7/8	47.63	41.14	38.86	44.50	66.54
DT-24	1-1/2	38.10	34.03	2	50.80	2-1/4	57.15	50.03	45.21	50.80	77.97
DT-32	2	50.80	45.97	2-3/4	69.85	3	76.20	67.56	62.73	69.80	107.18

Connects metric tube

Part No.	Tube O.D. D	E Min.	Width across flat		A	B	l	L
			h	H				
DT-2M	2	1.7	9.5	12	12.9	15.3	15.7	22.3
DT-3M	3	2.4	9.5	12	12.9	15.3	15.7	22.3
DT-4M	4	2.4	12.7	12	13.7	16.1	18.8	25.4
DT-6M	6	4.8	12.7	14	15.3	17.7	19.6	27.0
DT-8M	8	6.4	14.3	16	16.2	18.6	21.3	28.8
DT-10M	10	7.9	17.5	19	17.2	19.5	23.9	31.5
DT-12M	12	9.5	20.6	22	22.8	22.0	25.9	36.0
DT-15M	15	11.9	25.4	25	24.4	22.0	28.7	38.8
DT-16M	16	12.7	25.4	25	24.4	22.0	28.7	38.8
DT-18M	18	15.1	27.0	30	24.4	22.0	29.7	39.8
DT-20M	20	15.9	31.8	32	26.0	22.0	32.5	42.6
DT-22M	22	18.3	31.8	32	26.0	22.0	32.5	42.6
DT-25M	25	21.8	36.0	38	31.3	26.5	36.8	49.1
DT-28M	28	21.8	41.0	46	36.6	36.6	43.2	64.0
DT-32M	32	28.6	46.0	50	42.0	41.6	49.3	72.3
DT-38M	38	33.7	55.0	60	49.4	47.9	56.4	84.0

Union Cross DX

Note :
Cross may be made from
plate stock

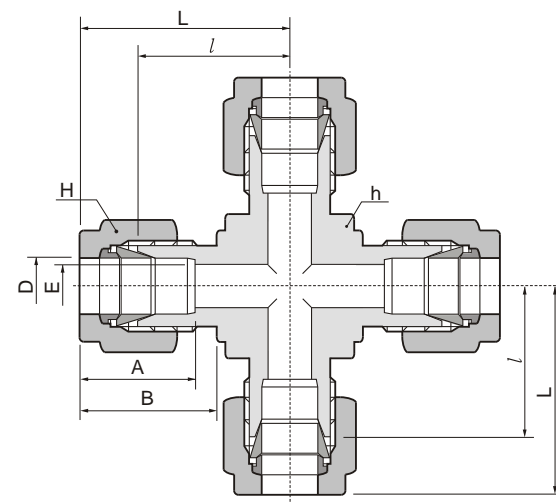
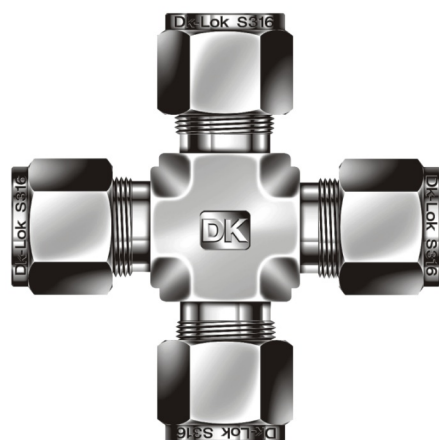

Connects fractional tube

Part No.	Tube O.D. D		E Min.	Width across flat				A	B	l	L
	in	mm		h		H					
				in	mm	in	mm				
DX-1	1/16	1.59	1.27	3/8	9.52	5/16	7.93	8.63	10.92	14.00	17.88
DX-2	1/8	3.17	2.28	3/8	9.52	7/16	11.11	12.70	15.24	15.74	22.35
DX-3	3/16	4.76	3.04	1/2	12.70	1/2	12.70	13.71	16.00	17.78	24.38
DX-4	1/4	6.35	4.82	1/2	12.70	9/16	14.28	15.24	17.78	19.55	26.92
DX-5	5/16	7.93	6.35	1/2	12.70	5/8	15.87	16.25	18.54	21.33	28.70
DX-6	3/8	9.52	7.11	11/16	17.46	11/16	17.46	16.76	19.30	23.11	30.48
DX-8	1/2	12.70	10.41	13/16	20.64	7/8	22.22	22.86	21.84	25.90	36.06
DX-10	5/8	15.87	12.70	13/16	20.64	1	25.40	24.38	21.84	28.70	38.80
DX-12	3/4	19.05	15.74	1	25.40	1-1/8	28.58	24.38	21.84	29.71	39.87
DX-14	7/8	22.22	18.28	1-1/4	31.75	1-1/4	31.75	25.90	21.84	34.54	44.70
DX-16	1	25.40	22.35	1-27/64	36.12	1-1/2	38.10	31.24	26.41	36.83	49.02
DX-20	1-1/4	31.75	27.68	1-11/16	42.86	1-7/8	47.63	41.14	38.86	44.50	66.54
DX-24	1-1/2	38.10	34.03	2	50.80	2-1/4	57.15	50.03	45.21	50.80	77.97
DX-32	2	50.80	45.97	2-3/4	69.85	3	76.20	67.56	62.73	69.80	107.18

Connects metric tube

Part No.	Tube O.D. D	E Min.	Width across flat		A	B	l	L
			h	H				
DX-3M	3	2.4	9.5	12	12.9	15.3	15.7	22.3
DX-4M	4	2.4	12.7	12	13.7	16.1	18.8	25.4
DX-6M	6	4.8	12.7	14	15.3	17.7	19.6	27.0
DX-8M	8	6.4	14.3	16	16.2	18.6	21.3	28.8
DX-10M	10	7.9	17.5	19	17.2	19.5	23.9	31.5
DX-12M	12	9.5	20.6	22	22.8	22.0	25.9	36.0
DX-15M	15	11.9	25.4	25	24.4	22.0	28.7	38.8
DX-16M	16	12.7	25.4	25	24.4	22.0	28.7	38.8
DX-18M	18	15.1	27.0	30	24.4	22.0	29.7	39.8
DX-20M	20	15.9	31.8	32	26.0	22.0	32.5	42.6
DX-22M	22	18.3	31.8	32	26.0	22.0	32.5	42.6
DX-25M	25	21.8	36.0	38	31.3	26.5	36.8	49.1
DX-28M	28	21.8	41.0	46	36.6	36.6	43.2	64.0
DX-32M	32	28.6	46.0	50	42.0	41.6	49.3	72.3
DX-38M	38	33.7	55.0	60	49.4	47.9	56.4	84.0

A, B & L are approximate figures in finger-tight.

Bulkhead Union DUB

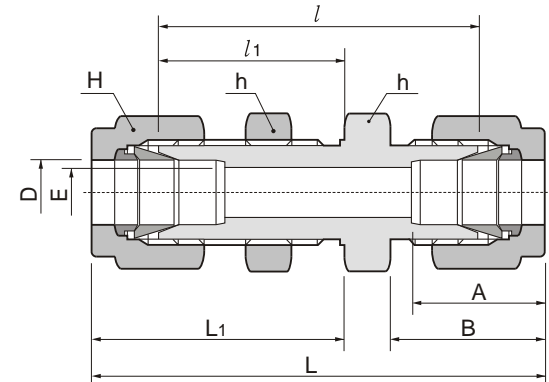
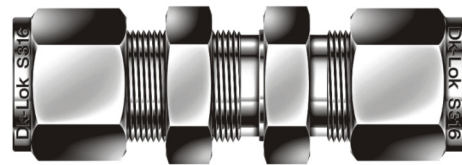

Connects fractional tube

Part No.	Tube O.D.		E Min.	Width across flat				A	B	l	l ₁	L	L ₁	Panel Hole Drill size	Panel Max Thickness
	in	mm		h	H	in	mm								
DUB-1	1/16	1.59	1.27	5/16	7.93	5/16	7.93	8.63	10.92	23.87	13.46	31.50	17.27	5.16	3.05
DUB-2	1/8	3.17	2.28	1/2	12.70	7/16	11.11	12.70	15.24	38.10	24.63	51.30	31.24	8.33	12.70
DUB-3	3/16	4.76	3.04	9/16	14.28	1/2	12.70	13.71	16.00	40.38	25.40	53.59	32.00	9.92	12.70
DUB-4	1/4	6.35	4.82	5/8	15.87	9/16	14.28	15.24	17.78	42.92	26.16	57.65	33.52	11.50	10.16
DUB-5	5/16	7.93	6.35	11/16	17.46	5/8	15.87	16.25	18.54	45.97	28.44	60.70	35.81	13.09	11.17
DUB-6	3/8	9.52	7.11	3/4	19.05	11/16	17.46	16.76	19.30	47.49	29.46	62.23	36.83	14.68	11.17
DUB-8	1/2	12.70	10.41	15/16	23.81	7/8	22.22	22.86	21.84	50.80	31.75	71.12	41.91	19.44	12.70
DUB-10	5/8	15.87	12.70	1-1/16	26.98	1	25.40	24.38	21.84	52.32	32.51	72.64	42.67	22.62	12.70
DUB-12	3/4	19.05	15.74	1-3/16	30.16	1-1/8	28.58	24.38	21.84	58.67	37.33	78.99	47.49	25.79	16.76
DUB-14	7/8	22.22	18.28	1-3/8	34.92	1-1/4	31.75	25.90	21.84	64.26	42.92	84.58	53.08	28.97	19.05
DUB-16	1	25.40	22.35	1-5/8	41.27	1-1/2	38.10	31.24	26.41	71.37	45.21	95.75	57.40	33.73	19.05
DUB-20	1-1/4	31.75	27.68	1-7/8	47.63	1-7/8	47.63	41.14	38.86	78.99	47.75	123.19	69.85	41.67	19.05
DUB-24	1-1/2	38.10	34.03	2-1/4	57.15	2-1/4	57.15	50.03	45.21	84.83	49.27	139.19	76.45	49.61	19.05
DUB-32	2	50.80	45.97	2-3/4	69.85	3	76.20	67.56	62.73	105.66	56.38	180.34	93.72	57.94	19.05

Connects metric tube

Part No.	Tube O.D.		E Min.	Width across flat				A	B	l	l ₁	L	L ₁	Panel Hole Drill size	Panel Max Thickness
	in	mm		h	H	in	mm								
DUB-3M		3	2.4	14	12	12.9	15.3	38.1	24.6	51.3	31.2	8.3	12.7		
DUB-4M		4	2.4	14	12	13.7	16.1	40.4	25.4	53.6	32.0	9.9	12.7		
DUB-6M		6	4.8	16	14	15.3	17.7	42.9	26.2	57.7	33.6	11.5	10.2		
DUB-8M		8	6.4	18	16	16.2	18.6	46.0	28.6	61.0	36.1	13.1	11.2		
DUB-10M		10	7.9	22	19	17.2	19.5	48.5	29.4	63.7	37.0	16.2	11.2		
DUB-12M		12	9.5	24	22	22.8	22.0	50.8	31.8	71.0	41.9	19.5	12.7		
DUB-15M		15	11.9	27	25	24.4	22.0	52.3	32.5	72.5	42.6	22.8	12.7		
DUB-16M		16	12.7	27	25	24.4	22.0	52.3	32.5	72.5	42.6	22.8	12.7		
DUB-18M		18	15.1	30	30	24.4	22.0	58.7	37.3	78.9	47.4	26.0	16.8		
DUB-20M		20	15.9	35	32	26.0	22.0	64.3	42.9	84.5	53.0	29.0	17.0		
DUB-22M		22	18.3	35	32	26.0	22.0	64.3	42.9	84.5	53.0	29.0	19.1		
DUB-25M		25	21.8	41.3	38	31.3	26.5	71.4	45.2	95.9	57.5	33.7	19.1		
DUB-32M		32	28.6	50	50	42.0	41.6	82.3	49.5	128.3	72.5	42.5	19.0		
DUB-38M		38	33.7	60	60	49.4	47.9	89.4	51.5	144.6	79.1	50.5	19.0		

Male Connector DMC-N

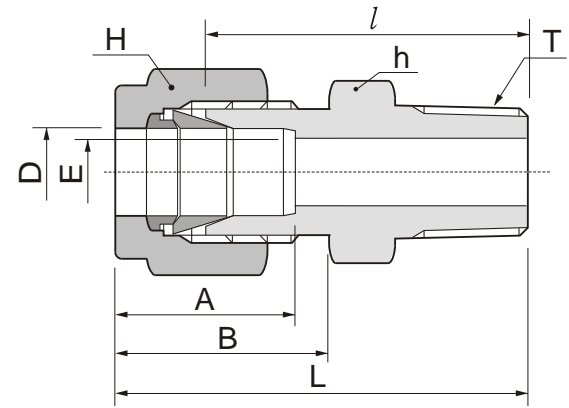
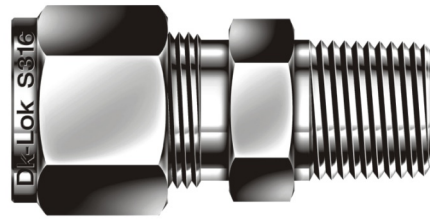

Connects fractional tube to female NPT thread

Part No.	Tube O.D.		T (NPT)	E Min.	Width across flat				A	B	l	L
	D				h		H					
	in	mm			in	mm	in	mm				
DMC 1-1N	1/16	1.59	1/16	1.27	5/16	7.93	5/16	7.93	8.63	10.92	20.00	23.83
DMC 1-2N	1/16	1.59	1/8	1.27	7/16	11.11	5/16	7.93	8.63	10.92	22.35	26.23
DMC 1-4N	1/16	1.59	1/4	1.27	9/16	14.28	5/16	7.93	8.63	10.92	27.17	30.98
DMC 2-1N	1/8	3.17	1/16	2.28	7/16	11.11	7/16	11.11	12.70	15.24	23.11	29.71
DMC 2-2N	1/8	3.17	1/8	2.28	7/16	11.11	7/16	11.11	12.70	15.24	23.87	30.48
DMC 2-4N	1/8	3.17	1/4	2.28	9/16	14.28	7/16	11.11	12.70	15.24	28.95	35.56
DMC 2-6N	1/8	3.17	3/8	2.28	11/16	17.46	7/16	11.11	12.70	15.24	29.21	35.81
DMC 2-8N	1/8	3.17	1/2	2.28	7/8	22.22	7/16	11.11	12.70	15.24	35.56	42.16
DMC 3-2N	3/16	4.76	1/8	3.04	7/16	11.11	1/2	12.70	13.71	16.00	24.63	31.24
DMC 3-4N	3/16	4.76	1/4	3.04	9/16	14.28	1/2	12.70	13.71	16.00	29.71	36.32
DMC 4-1N	1/4	6.35	1/16	4.82	1/2	12.70	9/16	14.28	15.24	17.78	25.40	32.76
DMC 4-2N	1/4	6.35	1/8	4.82	1/2	12.70	9/16	14.28	15.24	17.78	25.40	32.76
DMC 4-4N	1/4	6.35	1/4	4.82	9/16	14.28	9/16	14.28	15.24	17.78	30.48	37.84
DMC 4-6N	1/4	6.35	3/8	4.82	11/16	17.46	9/16	14.28	15.24	17.78	30.98	38.35
DMC 4-8N	1/4	6.35	1/2	4.82	7/8	22.22	9/16	14.28	15.24	17.78	37.33	44.70
DMC 4-12N	1/4	6.35	3/4	4.82	1-1/16	26.98	9/16	14.28	15.24	17.78	38.86	46.22
DMC 5-2N	5/16	7.93	1/8	4.82	9/16	14.28	5/8	15.87	16.25	18.54	26.67	34.03
DMC 5-4N	5/16	7.93	1/4	6.35	9/16	14.28	5/8	15.87	16.25	18.54	31.24	38.60
DMC 5-6N	5/16	7.93	3/8	6.35	11/16	17.46	5/8	15.87	16.25	18.54	31.75	39.11
DMC 5-8N	5/16	7.93	1/2	6.35	7/8	22.22	5/8	15.87	16.25	18.54	38.11	45.60
DMC 6-2N	3/8	9.52	1/8	4.82	5/8	15.87	11/16	17.46	16.76	19.30	27.94	35.30
DMC 6-4N	3/8	9.52	1/4	7.11	5/8	15.87	11/16	17.46	16.76	19.30	32.51	39.87
DMC 6-6N	3/8	9.52	3/8	7.11	11/16	17.46	11/16	17.46	16.76	19.30	32.51	39.87
DMC 6-8N	3/8	9.52	1/2	7.11	7/8	22.22	11/16	17.46	16.76	19.30	38.86	46.22
DMC 6-12N	3/8	9.52	3/4	7.11	1-1/16	26.98	11/16	17.46	16.76	19.30	40.38	47.75
DMC 8-2N	1/2	12.70	1/8	4.82	13/16	20.64	7/8	22.22	22.86	21.84	28.70	38.86
DMC 8-4N	1/2	12.70	1/4	7.11	13/16	20.64	7/8	22.22	22.86	21.84	33.27	43.43
DMC 8-6N	1/2	12.70	3/8	9.65	13/16	20.64	7/8	22.22	22.86	21.84	33.27	43.43
DMC 8-8N	1/2	12.70	1/2	10.41	7/8	22.22	7/8	22.22	22.86	21.84	38.86	49.02
DMC 8-12N	1/2	12.70	3/4	10.41	1-1/16	26.98	7/8	22.22	22.86	21.84	40.38	50.54
DMC 8-16N	1/2	12.70	1	10.41	1-3/8	34.92	7/8	22.22	22.86	21.84	46.99	57.15
DMC 10-6N	5/8	15.87	3/8	9.65	15/16	23.81	1	25.40	24.38	21.84	34.03	44.19
DMC 10-8N	5/8	15.87	1/2	11.93	15/16	23.81	1	25.40	24.38	21.84	38.86	49.02
DMC 10-12N	5/8	15.87	3/4	12.70	1-1/16	26.98	1	25.40	24.38	21.84	40.38	50.54
DMC 12-8N	3/4	19.05	1/2	11.93	1-1/16	26.98	1-1/8	28.58	24.38	21.84	40.38	50.54
DMC 12-12N	3/4	19.05	3/4	15.74	1-1/16	26.98	1-1/8	28.58	24.38	21.84	40.38	50.54
DMC 12-16N	3/4	19.05	1	15.74	1-3/8	34.92	1-1/8	28.58	24.38	21.84	46.99	57.15
DMC 14-12N	7/8	22.22	3/4	15.74	1-3/16	30.16	1-1/4	31.75	25.90	21.84	40.38	50.54
DMC 14-16N	7/8	22.22	1	18.28	1-3/8	34.92	1-1/4	31.75	25.90	21.84	46.99	57.15
DMC 16-8N	1	25.40	1/2	11.93	1-3/8	34.92	1-1/2	38.10	31.24	26.41	45.21	57.40
DMC 16-12N	1	25.40	3/4	15.74	1-3/8	34.92	1-1/2	38.10	31.24	26.41	45.21	57.40
DMC 16-16N	1	25.40	1	22.35	1-3/8	34.92	1-1/2	38.10	31.24	26.41	50.03	62.23
DMC 20-16N	1-1/4	31.75	1	22.35	1-3/4	44.45	1-7/8	47.63	41.14	38.86	55.11	77.21
DMC 20-20N	1-1/4	31.75	1-1/4	27.68	1-3/4	44.45	1-7/8	47.63	41.14	38.86	55.11	77.21
DMC 20-24N	1-1/4	31.75	1-1/2	27.68	1-3/4	44.45	1-7/8	47.63	41.14	38.86	60.54	82.64
DMC 24-20N	1-1/2	38.10	1-1/4	27.68	2-1/8	53.98	2-1/4	57.15	50.03	45.21	59.42	86.60
DMC 24-24N	1-1/2	38.10	1-1/2	34.03	2-1/8	53.98	2-1/4	57.15	50.03	45.21	61.72	88.90
DMC 24-32N	1-1/2	38.10	2	34.03	2-3/4	69.85	2-1/4	57.15	50.03	45.21	62.42	99.75
DMC 32-8N	2	50.80	1/2	11.93	2-3/4	69.85	3	76.20	67.56	62.73	68.40	105.73
DMC 32-20N	2	50.80	1-1/4	45.97	2-3/4	69.85	3	76.20	67.56	62.73	71.40	108.73
DMC 32-24N	2	50.80	1-1/2	45.97	2-3/4	69.85	3	76.20	67.56	62.73	75.50	112.83
DMC 32-32N	2	50.80	2	45.97	2-3/4	69.85	3	76.20	67.56	62.73	76.20	113.53

A, B & L are approximate figures in finger-tight.

Male Connector DMC-R

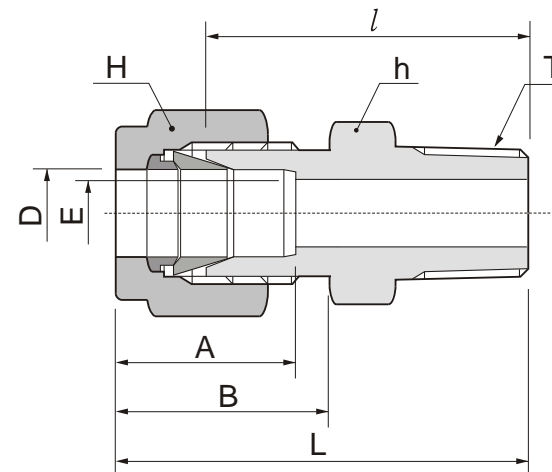
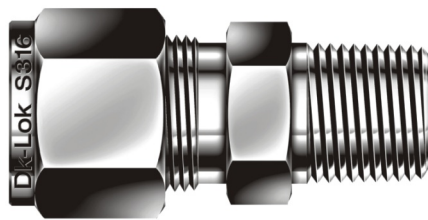

Connects metric tube to female ISO tapered thread

Part No.	Tube O.D. D	T R(PT)	E Min.	Width across flat		A	B	l	L
				h	H				
DMC 2M-2R	2	1/8	1.7	12	12	12.9	15.3	23.9	30.5
DMC 3M-2R	3	1/8	2.4	12	12	12.9	15.3	23.1	29.7
DMC 3M-4R	3	1/4	2.4	14	12	12.9	15.3	29.0	35.6
DMC 4M-2R	4	1/8	2.4	12	12	13.7	16.1	24.6	31.2
DMC 4M-4R	4	1/4	2.4	14	12	13.7	16.1	29.7	36.3
DMC 6M-2R	6	1/8	4.8	14	14	15.3	17.7	25.4	32.8
DMC 6M-4R	6	1/4	4.8	14	14	15.3	17.7	30.2	37.6
DMC 6M-6R	6	3/8	4.8	18	14	15.3	17.7	31.0	38.4
DMC 6M-8R	6	1/2	4.8	22	14	15.3	17.7	36.6	44.0
DMC 8M-2R	8	1/8	4.8	15	16	16.2	18.6	26.7	34.2
DMC 8M-4R	8	1/4	6.4	15	16	16.2	18.6	31.2	38.7
DMC 8M-6R	8	3/8	6.4	18	16	16.2	18.6	31.8	39.2
DMC 8M-8R	8	1/2	6.4	22	16	16.2	18.6	37.3	44.8
DMC 10M-2R	10	1/8	4.8	18	19	17.2	19.5	28.7	36.3
DMC 10M-4R	10	1/4	7.1	18	19	17.2	19.5	33.3	40.9
DMC 10M-6R	10	3/8	7.9	18	19	17.2	19.5	33.3	40.9
DMC 10M-8R	10	1/2	7.9	22	19	17.2	19.5	38.1	45.7
DMC 12M-4R	12	1/4	7.1	22	22	22.8	22.0	33.3	43.4
DMC 12M-6R	12	3/8	9.5	22	22	22.8	22.0	33.3	43.4
DMC 12M-8R	12	1/2	9.5	22	22	22.8	22.0	38.1	48.2
DMC 12M-12R	12	3/4	9.5	27	22	22.8	22.0	38.9	49.0
DMC 15M-8R	15	1/2	11.9	24	25	24.4	22.0	38.9	49.0
DMC 16M-4R	16	1/4	7.1	24	25	24.4	22.0	34.0	44.1
DMC 16M-6R	16	3/8	9.5	24	25	24.4	22.0	34.0	44.1
DMC 16M-8R	16	1/2	11.9	24	25	24.4	22.0	38.9	49.0
DMC 16M-12R	16	3/4	12.7	27	25	24.4	22.0	38.9	49.0
DMC 18M-8R	18	1/2	11.9	27	30	24.4	22.0	40.4	50.5
DMC 18M-12R	18	3/4	15.1	27	30	24.4	22.0	40.4	50.5
DMC 20M-8R	20	1/2	11.9	30	32	26.0	22.0	42.2	52.3
DMC 20M-12R	20	3/4	15.9	30	32	26.0	22.0	42.2	52.3
DMC 22M-12R	22	3/4	15.9	30	32	26.0	22.0	42.2	52.3
DMC 22M-16R	22	1	18.3	35	32	26.0	22.0	47.8	57.9
DMC 25M-12R	25	3/4	15.9	35	38	31.3	26.5	45.2	57.5
DMC 25M-16R	25	1	21.8	35	38	31.3	26.5	50.0	62.3
DMC 28M-16R	28	1	21.8	41	46	36.6	36.6	51.6	72.4
DMC 28M-20R	28	1-1/4	21.8	46	46	36.6	36.6	52.3	73.1
DMC 32M-20R	32	1-1/4	28.6	46	50	42.0	41.6	56.6	79.6
DMC 38M-24R	38	1-1/2	33.7	55	60	49.4	47.9	64.0	91.6

Thermocouple Connector DMCT

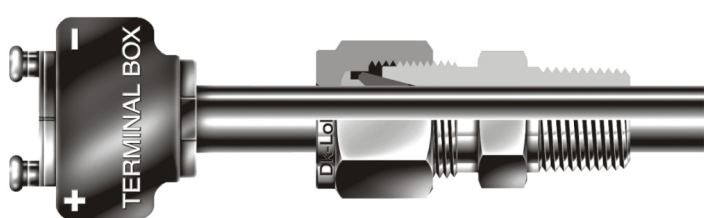

Dk-Lok thermocouple connector has no shoulder nor sizing angle inside the fitting, the features enable thermocoupler to go through fitting's thread end. Suffix "T" to Male Connector identifier.

Example : **DMCT 8-8N-S** for ordering Thermocouple connector
O.D 1/2 x 1/2 NPT S316.

Assembly Instructions

1. Position the length of the Thermocouple passed through fitting's thread end and hold it to prevent shifting during assembly.
2. Turn the nut 1-1/4 after finger tight with a wrench by holding the body with a back up wrench for size 1/4" (6mm) or above.

Male Connector for Bonded Seal **DMC-G**

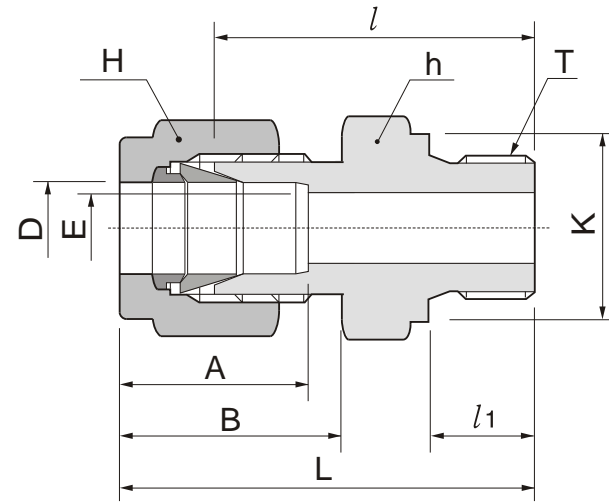
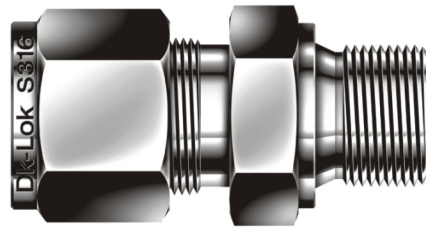

Connects fractional tube to female ISO parallel thread

Part No.	Tube O.D. D		T (PF)	E Min.	Width across flat				A	B	l	l ₁	L	K
	in	mm			h	H	in	mm						
DMC 2-2G	1/8	3.17	1/8	2.28	9/16	14.28	7/16	11.11	12.70	15.24	23.37	7.11	29.97	13.72
DMC 2-4G	1/8	3.17	1/4	2.28	3/4	19.05	7/16	11.11	12.70	15.24	28.70	11.18	35.31	18.03
DMC 2-6G	1/8	3.17	3/8	2.28	7/8	22.22	7/16	11.11	12.70	15.24	29.72	11.18	36.21	21.84
DMC 4-2G	1/4	6.35	1/8	2.28	9/16	14.28	9/16	14.28	15.24	17.78	24.89	7.11	32.26	13.72
DMC 4-4G	1/4	6.35	1/4	4.82	3/4	19.05	9/16	14.28	15.24	17.78	30.23	11.18	37.59	18.03
DMC 4-6G	1/4	6.35	3/8	4.82	7/8	22.22	9/16	14.28	15.24	17.78	31.50	11.18	38.86	21.84
DMC 4-8G	1/4	6.35	1/2	4.82	1-1/16	26.98	9/16	14.28	15.24	17.78	37.34	14.22	44.70	25.91
DMC 6-4G	3/8	9.53	1/4	4.82	3/4	19.05	11/16	17.46	16.76	19.30	31.75	11.18	39.12	18.03
DMC 6-6G	3/8	9.53	3/8	7.11	7/8	22.22	11/16	17.46	16.76	19.30	33.02	11.18	40.39	21.84
DMC 6-8G	3/8	9.53	1/2	7.11	1-1/16	26.98	11/16	17.46	16.76	19.30	38.86	14.22	46.23	25.91
DMC 8-4G	1/2	12.70	1/4	7.11	13/16	20.64	7/8	22.22	22.86	21.84	32.51	11.18	42.67	18.03
DMC 8-6G	1/2	12.70	3/8	9.65	7/8	22.22	7/8	22.22	22.86	21.84	33.02	11.18	43.18	21.84
DMC 8-8G	1/2	12.70	1/2	10.41	1-1/16	26.98	7/8	22.22	22.86	21.84	38.86	14.22	49.02	25.91
DMC 12-8G	3/4	19.05	1/2	11.93	1-1/16	26.98	1-1/8	28.58	24.38	21.84	38.86	14.22	49.02	25.91
DMC 12-12G	3/4	19.05	3/4	15.74	1-5/16	33.33	1-1/8	28.58	24.38	21.84	42.67	15.75	52.83	32.00
DMC 16-8G	1	25.40	1/2	11.93	1-3/8	34.92	1-1/2	38.10	31.24	26.41	43.69	14.22	55.88	25.91
DMC 16-16G	1	25.40	1	22.35	1-5/8	41.27	1-1/2	38.10	31.24	26.41	47.75	18.29	59.94	39.12
DMC 20-20G	1-1/4	31.75	1-1/4	27.68	2	50.80	1-7/8	47.63	41.14	38.86	51.16	20.00	73.26	49.00
DMC 24-24G	1-1/2	38.10	1-1/2	34.03	2-1/4	57.15	2-1/4	57.15	50.03	45.21	57.57	22.00	84.75	55.00

Connects metric tube to female ISO parallel thread

Part No.	Tube O.D. D		T G(PF)	E Min.	Width across flat		A	B	l	l ₁	L	K
	in	mm			h	H						
DMC 2M-2G	2	1/8	1.7	14	12	12.9	15.3	23.4	7.1	30.0	13.8	
DMC 3M-2G	3	1/8	2.4	14	12	12.9	15.3	23.4	7.1	30.0	13.8	
DMC 3M-4G	3	1/4	2.4	19	12	12.9	15.3	28.7	11.2	35.3	18.0	
DMC 4M-2G	4	1/8	2.4	14	12	13.7	16.1	24.1	7.1	30.7	13.8	
DMC 4M-4G	4	1/4	2.4	19	12	13.7	16.1	29.4	11.2	36.0	18.0	
DMC 6M-2G	6	1/8	4.0	14	14	15.3	17.7	24.9	7.1	32.3	13.8	
DMC 6M-4G	6	1/4	4.8	19	14	15.3	17.7	30.2	11.2	37.6	18.0	
DMC 6M-6G	6	3/8	4.8	22	14	15.3	17.7	31.5	11.2	38.9	21.8	
DMC 6M-8G	6	1/2	4.8	27	14	15.3	17.7	37.3	14.2	44.7	26.0	
DMC 8M-2G	8	1/8	4.0	15	16	16.2	18.6	25.7	7.1	33.2	13.8	
DMC 8M-4G	8	1/4	6.4	19	16	16.2	18.6	31.0	11.2	38.5	13.8	
DMC 8M-6G	8	3/8	6.4	22	16	16.2	18.6	32.3	11.2	39.8	21.8	
DMC 8M-8G	8	1/2	6.4	27	16	16.2	18.6	38.1	14.2	45.6	26.0	
DMC 10M-4G	10	1/4	6.4	19	19	17.2	19.5	31.8	11.2	39.4	18.0	
DMC 10M-6G	10	3/8	7.9	22	19	17.2	19.5	33.0	11.2	40.6	21.8	
DMC 10M-8G	10	1/2	7.9	27	19	17.2	19.5	38.9	14.2	46.5	26.0	
DMC 12M-4G	12	1/4	5.9	22	22	22.8	22.0	32.5	11.2	42.6	18.0	
DMC 12M-6G	12	3/8	7.9	22	22	22.8	22.0	33.0	11.2	43.1	21.8	
DMC 12M-8G	12	1/2	9.5	27	22	22.8	22.0	38.9	14.2	49.0	26.0	
DMC 12M-12G	12	3/4	9.5	32	22	22.8	22.0	42.7	15.7	52.8	32.0	
DMC 16M-6G	16	3/8	7.9	24	25	24.4	22.0	33.8	11.2	43.9	21.8	
DMC 16M-8G	16	1/2	11.9	27	25	24.4	22.0	38.9	14.2	49.0	26.0	
DMC 18M-8G	18	1/2	11.9	27	30	24.4	22.0	38.9	14.2	49.0	26.0	
DMC 18M-12G	18	3/4	15.1	35	30	24.4	22.0	42.7	15.7	52.8	32.0	
DMC 20M-8G	20	1/2	11.9	30	32	26.0	22.0	40.4	14.2	50.5	26.0	
DMC 20M-12G	20	3/4	15.9	35	32	26.0	22.0	42.7	15.7	52.8	32.0	
DMC 22M-12G	22	3/4	15.9	35	32	26.0	22.0	42.7	15.7	52.8	32.0	
DMC 22M-16G	22	1	18.3	41	32	26.0	22.0	45.2	18.3	55.3	39.0	
DMC 25M-12G	25	3/4	15.9	35	38	31.3	26.5	45.2	15.7	57.5	32.0	
DMC 25M-16G	25	1	19.8	41	38	31.3	26.5	47.8	18.3	60.1	39.0	
DMC 28M-16G	28	1	19.8	41	46	36.6	36.6	49.3	18.3	70.1	39.0	
DMC 28M-20G	28	1-1/4	21.8	50	46	36.6	36.6	53.1	19.8	73.9	49.0	
DMC 32M-20G	32	1-1/4	25.0	50	50	42.0	41.6	55.9	19.8	78.9	49.0	
DMC 38M-24G	38	1-1/2	31.8	55	60	49.4	47.9	63.2	22.1	90.8	54.7	

A, B & L are approximate figures in finger-tight.

ISO Pipe Thread

The International Standards Organization created the ISO 228/1 and 7/1 threads to standardize the nomenclature of several international pipe threads.

228/1

The ISO 228/1 is a parallel thread that is no sealing threads. The pressure tight seal is usually made metal to metal against the female port or with a gasket.

The 228/1 is described in following codes.

1. BS 2779 (BSPP)
2. DIN-ISO 228/1
3. JIS B0202 (PF)
4. ISO 228/1

The 228/1 threads sealing available in Dk-Lok are listed below.

A self-centering taper is constructed at the hex. This taper centers a bonded washer to seal to the surface surrounding the female thread.

DGB Bonded Seal Gasket

(Buna inner ring bonded to carbon steel outer ring)

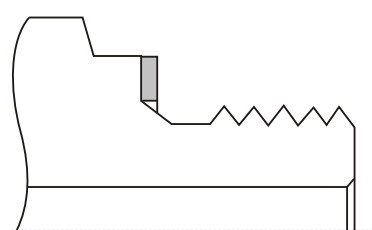

Sealing by compression against face of body
Reference DIN 3852 Type A

Ordering Number	E		H		D	
	(mm)	(in.)	(mm)	(in.)	(mm)	(in.)
DGB-2-	10.4	0.41	2.0	0.08	16.0	0.63
DGB-4-	13.7	0.54	2.0	0.08	20.6	0.81
DGB-6-	17.3	0.68	2.0	0.08	23.9	0.94
DGB-8-	21.6	0.85	2.5	0.10	28.7	1.13
DGB-12-	27.2	1.06	2.5	0.10	35.1	1.38
DGB-16-	33.8	1.33	2.5	0.10	42.9	1.69
DGB-20-	42.4	1.67	2.5	0.10	51.05	2.01
DGB-24-	48.8	1.92	2.5	0.10	59.18	2.33

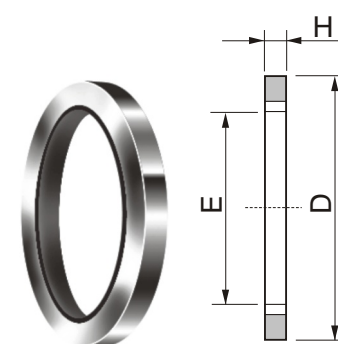

A metal gasket performs the sealing between the reverse bevel of the fitting and the face of the female threaded component.

DGC Copper Gasket

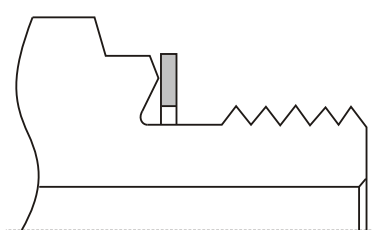

Sealing by gasket (washer)
Reference DIN 3852 Type B

Ordering Number	E		H		D	
	(mm)	(in.)	(mm)	(in.)	(mm)	(in.)
DGC-2-	10	0.39	2.0	0.08	18	0.71
DGC-4-	14	0.55	2.0	0.08	22	0.86
DGC-6-	17	0.67	2.0	0.08	26	1.02
DGC-8-	22	0.86	2.0	0.08	32	1.26
DGC-12-	27	1.06	2.0	0.08	38	1.50
DGC-16-	34	1.34	2.0	0.08	42	1.65
DGC-20-	42.2	1.66	2.0	0.08	49.8	1.96
DGC-24-	48.0	1.89	2.0	0.08	58.4	2.30

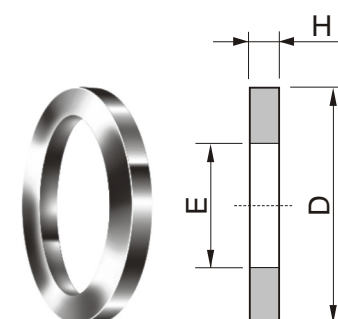

A gasket is dropped into the flat bottom of the female thread. The face of the male thread exerts a load on the gasket to seal.

DGG Copper Gasket

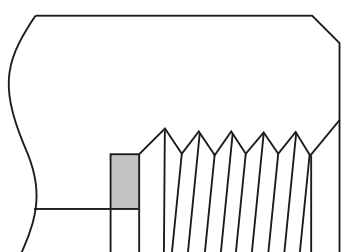

Sealing by gasket.
Reference DIN 3852 Type Y

Ordering Number	E		H		D	
	(mm)	(in.)	(mm)	(in.)	(mm)	(in.)
DGG-4-	7.6	0.30	1.8	0.07	10.7	0.42
DGG-6-	8.6	0.34	2.3	0.09	14.2	0.56
DGG-8-	9.1	0.36	2.5	0.10	17.8	0.70

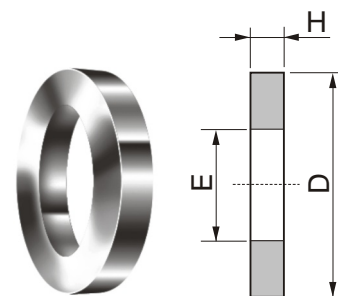

7/1

The ISO 7/1 is a tapered thread that is sealing threads working by interference fit. This still requires thread sealant for pressure-tight seal by filling the voids between threads further this prevents galling on piping threads. The sealant usually contains a lubricant.

The 7/1 is described in following codes.

1. BS 21(BSPT) 2. JIS B0203 (PT) 3. ISO 7/1 4. DIN 2999 (male thread only)

The 7/1 looks similar to the NPT thread. See how different they are as illustrated below.

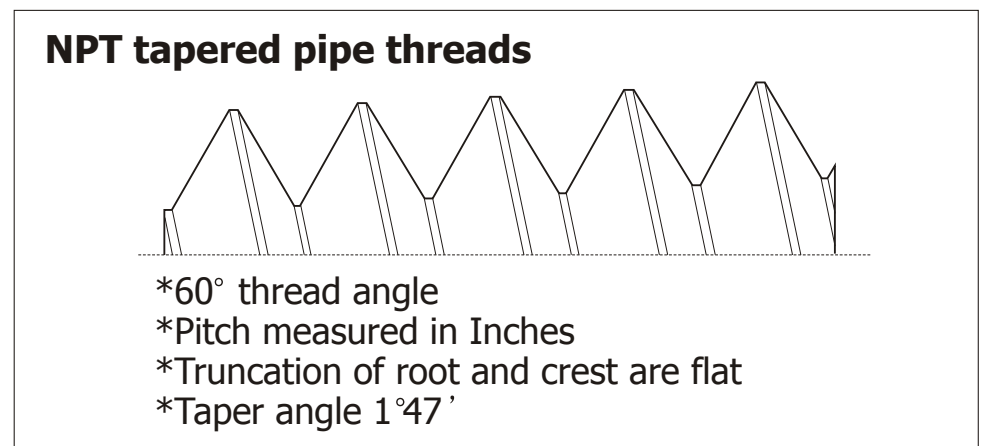
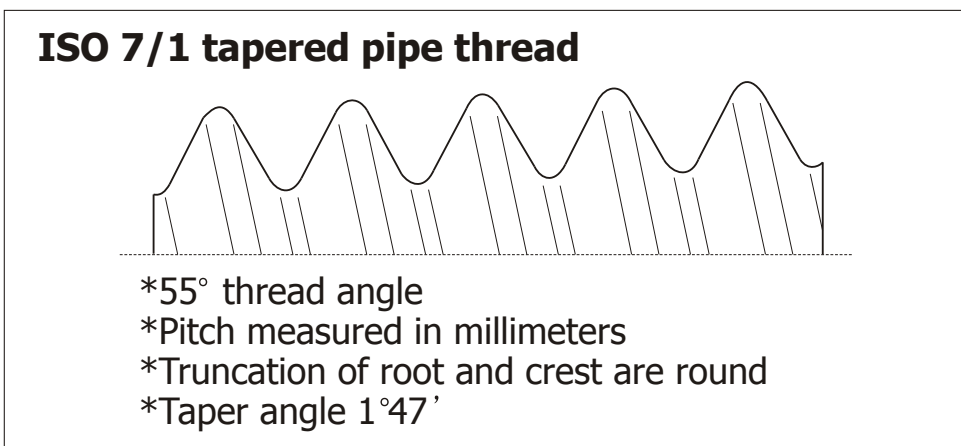

ISO Internal Parallel Pipe Thread

Diagram	Dk-Lok Pipe Thread Designator	ISO Female Parallel Pipe Size	Minimum Full Thread Depth L	Thread Minor Diameter D	Minimum Flat Diameter for DGB & DGC C
	2	1/8	0.31	0.337 / 0.348	0.59
	4	1/4	0.47	0.450 / 0.468	0.75
	6	3/8	0.47	0.588 / 0.606	0.91
	8	1/2	0.55	0.733 / 0.755	1.06
	12	3/4	0.63	0.949 / 0.971	1.30
	16	1	0.71	1.193 / 1.218	1.57

Male Connector for Metal Gasket **DOM**

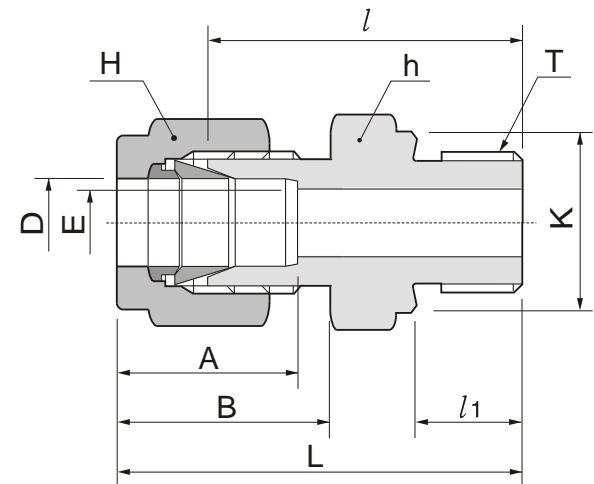
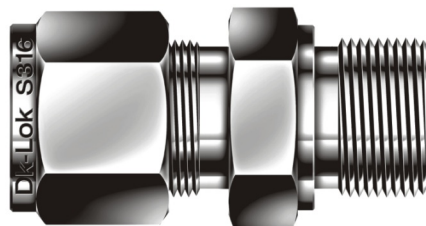

Connects fractional tube to female ISO parallel thread

Part No.	Tube O.D. D		T (PF)	E Min.	Width across flat				A	B	l	l ₁	L	K
	in	mm			h	H	in	mm						
DOM 2-2G	1/8	3.17	1/8	2.28	9/16	14.28	7/16	11.11	12.70	15.24	23.37	7.11	29.97	13.72
DOM 2-4G	1/8	3.17	1/4	2.28	3/4	19.05	7/16	11.11	12.70	15.24	28.70	11.18	35.31	18.03
DOM 2-6G	1/8	3.17	3/8	2.28	7/8	22.22	7/16	11.11	12.70	15.24	29.72	11.18	36.21	21.84
DOM 4-2G	1/4	6.35	1/8	2.28	9/16	14.28	9/16	14.28	15.24	17.78	24.89	7.11	32.26	13.72
DOM 4-4G	1/4	6.35	1/4	4.82	3/4	19.05	9/16	14.28	15.24	17.78	30.23	11.18	37.59	18.03
DOM 4-6G	1/4	6.35	3/8	4.82	7/8	22.22	9/16	14.28	15.24	17.78	31.50	11.18	38.86	21.84
DOM 4-8G	1/4	6.35	1/2	4.82	1-1/16	26.98	9/16	14.28	15.24	17.78	37.34	14.22	44.70	25.91
DOM 6-4G	3/8	9.53	1/4	4.82	3/4	19.05	11/16	17.46	16.76	19.30	31.75	11.18	39.12	18.03
DOM 6-6G	3/8	9.53	3/8	7.11	7/8	22.22	11/16	17.46	16.76	19.30	33.02	11.18	40.39	21.84
DOM 6-8G	3/8	9.53	1/2	7.11	1-1/16	26.98	11/16	17.46	16.76	19.30	38.86	14.22	46.23	25.91
DOM 8-4G	1/2	12.70	1/4	7.11	13/16	20.64	7/8	22.22	22.86	21.84	32.51	11.18	42.67	18.03
DOM 8-6G	1/2	12.70	3/8	9.65	7/8	22.22	7/8	22.22	22.86	21.84	33.02	11.18	43.18	21.84
DOM 8-8G	1/2	12.70	1/2	10.41	1-1/16	26.98	7/8	22.22	22.86	21.84	38.86	14.22	49.02	25.91
DOM 12-8G	3/4	19.05	1/2	11.93	1-1/16	26.98	1-1/8	28.58	24.38	21.84	38.86	14.22	49.02	25.91
DOM 12-12G	3/4	19.05	3/4	15.74	1-5/16	33.33	1-1/8	28.58	24.38	21.84	42.67	15.75	52.83	32.00
DOM 16-8G	1	25.40	1/2	11.93	1-3/8	34.92	1-1/2	38.10	31.24	26.41	43.69	14.22	55.88	25.91
DOM 16-16G	1	25.40	1	22.35	1-5/8	41.27	1-1/2	38.10	31.24	26.41	47.75	18.29	59.94	39.12
DOM 20-20G	1-1/4	31.75	1-1/4	27.68	2	50.80	1-7/8	47.63	41.14	38.86	51.16	20.00	73.26	49.00
DOM 24-24G	1-1/2	38.10	1-1/2	34.03	2-1/4	57.15	2-1/4	57.15	50.03	45.21	57.57	22.00	84.75	55.00

A, B & L are approximate figures in finger-tight.

Male Connector for Metal Gasket **DOM**

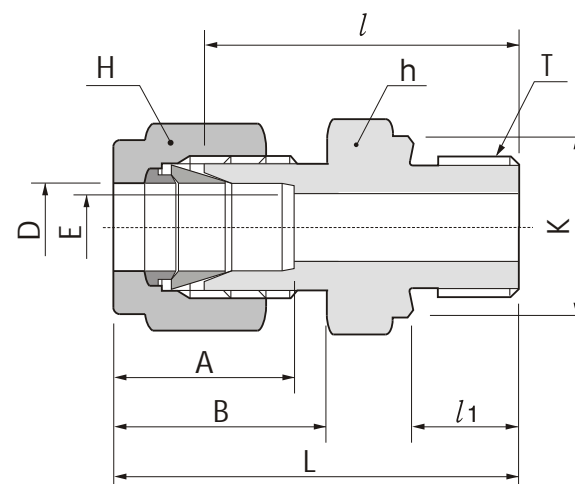
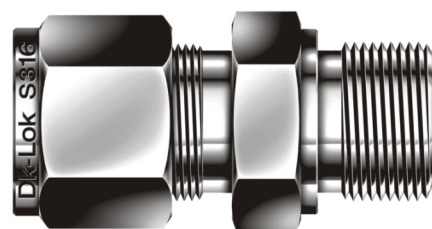

Connects metric tube to female ISO parallel thread

Part No.	Tube O.D.	T G(PF)	E Min.	Width across flat		A	B	l	l ₁	L	K
	D			h	H						
DOM 3M-2G	3	1/8	2.4	14	12	12.9	15.3	23.4	7.1	30.0	13.8
DOM 3M-4G	3	1/4	2.4	19	12	12.9	15.3	28.7	11.2	35.3	18.0
DOM 4M-2G	4	1/8	2.4	14	12	13.7	16.1	24.1	7.1	30.7	13.8
DOM 6M-2G	6	1/8	4.0	14	14	15.3	17.7	24.9	7.1	32.3	13.8
DOM 6M-4G	6	1/4	4.8	19	14	15.3	17.7	30.2	11.2	37.6	18.0
DOM 6M-6G	6	3/8	4.8	22	14	15.3	17.7	31.5	11.2	38.9	21.8
DOM 6M-8G	6	1/2	4.8	27	14	15.3	17.7	37.3	14.2	44.7	26.0
DOM 8M-2G	8	1/8	4.0	15	16	16.2	18.6	25.7	7.1	33.2	13.8
DOM 8M-4G	8	1/4	6.4	19	16	16.2	18.6	31.0	11.2	38.5	13.8
DOM 8M-6G	8	3/8	6.4	22	16	16.2	18.6	32.3	11.2	39.8	21.8
DOM 8M-8G	8	1/2	6.4	27	16	16.2	18.6	38.1	14.2	45.6	26.0
DOM 10M-4G	10	1/4	5.9	19	19	17.2	19.5	31.8	11.2	39.4	18.0
DOM 10M-6G	10	3/8	7.9	22	19	17.2	19.5	33.0	11.2	40.6	21.8
DOM 10M-8G	10	1/2	7.9	27	19	17.2	19.5	38.9	14.2	46.5	26.0
DOM 12M-4G	12	1/4	5.9	22	22	22.8	22.0	32.5	11.2	42.6	18.0
DOM 12M-6G	12	3/8	7.9	22	22	22.8	22.0	33.0	11.2	43.1	21.8
DOM 12M-8G	12	1/2	9.5	27	22	22.8	22.0	38.9	14.2	49.0	26.0
DOM 12M-12G	12	3/4	9.5	32	22	22.8	22.0	42.7	15.7	52.8	32.0
DOM 15M-8G	15	1/2	11.9	27	25	24.4	22.0	33.9	14.2	49.0	26.0
DOM 16M-6G	16	3/8	7.9	24	25	24.4	22.0	33.8	11.2	43.9	21.8
DOM 16M-8G	16	1/2	11.9	27	25	24.4	22.0	38.9	14.2	49.0	26.0
DOM 18M-8G	18	1/2	11.9	27	30	24.4	22.0	38.9	14.2	49.0	26.0
DOM 18M-12G	18	3/4	15.1	35	30	24.4	22.0	42.7	15.7	52.8	32.0
DOM 20M-8G	20	1/2	11.9	30	32	26.0	22.0	40.4	14.2	50.5	26.0
DOM 20M-12G	20	3/4	15.9	35	32	26.0	22.0	42.7	15.7	52.8	32.0
DOM 22M-12G	22	3/4	15.9	35	32	26.0	22.0	42.7	15.7	52.8	32.0
DOM 22M-16G	22	1	18.3	41	32	26.0	22.0	45.2	18.3	55.3	39.0
DOM 25M-12G	25	3/4	15.9	35	38	31.3	26.5	45.2	15.7	57.5	32.0
DOM 25M-16G	25	1	19.8	41	38	31.3	26.5	47.8	18.3	60.1	39.0
DOM 28M-16G	28	1	19.8	41	46	36.6	36.6	49.3	18.3	70.1	39.0
DOM 28M-20G	28	1-1/4	21.8	50	46	36.6	36.6	53.1	19.8	73.9	49.0
DOM 32M-20G	32	1-1/4	28.6	50	50	42.0	41.6	55.9	19.8	78.9	49.0
DOM 38M-24G	38	1-1/2	31.8	55	60	49.4	47.9	61.7	20.6	89.3	54.7

Vent Protector **DMD**

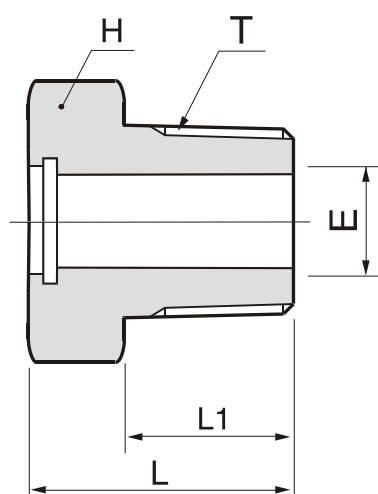
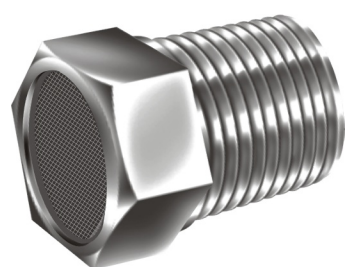

Part No.	T (NPT)	E Min.	H		L	L1
			in	mm		
DMD-4N	1/4	7.11	9/16	15.87	20.57	14.22
DMD-6N	3/8	10.40	11/16	17.46	20.57	14.22
DMD-8N	1/2	12.70	7/8	23.81	26.92	19.05
DMD-12N	3/4	16.00	1-1/16	26.98	28.70	19.05

Bore-thru pipe plug with Stainless Steel 40×40 mesh, 0.010 diameter wire screen.

DK-LOK vent protector, known as the mud dauber fittings, protects open ends of instruments, tubing, outlet vents by preventing foreign materials such as insects, debris from entering and clogging systems.

Standard S316 Stainless steel and Brass materials.

Bulkhead Male Connector **DMCB**

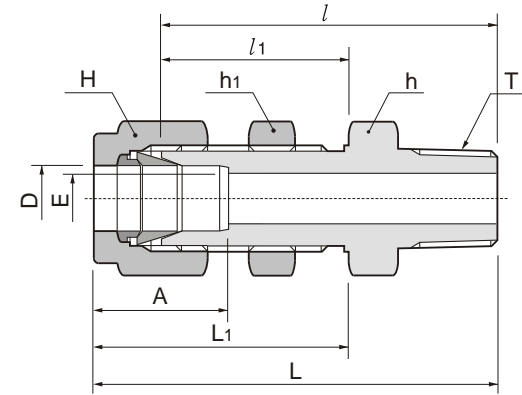
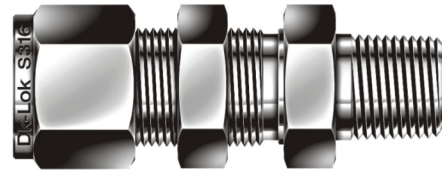

Connects fractional tube to female NPT thread

Part No.	Tube O.D. D		T (NPT)	E Min.	Width across flat				A	l	l1	L	L1	Panel Hole Drill size	Panel Max Thickness		
	in	mm			h	h1	H										
DMCB 2-2N	1/8	3.17	1/8	2.28	1/2	12.70	1/2	12.70	7/16	11.11	12.70	39.87	24.63	46.48	31.24	8.33	12.70
DMCB 4-2N	1/4	6.35	1/8	4.82	5/8	15.87	5/8	15.87	9/16	14.28	15.24	42.16	26.16	49.53	33.52	11.50	10.16
DMCB 4-4N	1/4	6.35	1/4	4.82	5/8	15.87	5/8	15.87	9/16	14.28	15.24	45.97	26.16	53.34	33.52	11.50	10.16
DMCB 6-4N	3/8	9.52	1/4	7.11	3/4	19.05	3/4	19.05	11/16	17.46	16.76	50.03	29.46	57.40	36.83	14.68	11.17
DMCB 6-6N	3/8	9.52	3/8	7.11	3/4	19.05	3/4	19.05	11/16	17.46	16.76	50.03	29.46	57.40	36.83	14.68	11.17
DMCB 6-8N	3/8	9.52	1/2	7.11	7/8	22.22	3/4	19.05	11/16	17.46	16.76	56.38	29.46	63.75	36.83	14.68	11.17
DMCB 8-6N	1/2	12.70	3/8	9.39	15/16	23.81	15/16	23.81	7/8	22.22	22.86	53.08	31.75	63.24	41.91	19.44	12.70
DMCB 8-8N	1/2	12.70	1/2	10.41	15/16	23.81	15/16	23.81	7/8	22.22	22.86	58.67	31.75	68.83	41.91	19.44	12.70
DMCB12-12N	3/4	19.05	3/4	15.74	1-3/16	30.16	1-3/16	30.16	1-1/8	28.58	24.38	66.04	37.33	76.20	47.49	25.76	16.76
DMCB16-16N	1	25.40	1	22.35	1-5/8	41.28	1-5/8	41.28	1-1/2	38.10	31.24	81.02	45.21	93.21	57.40	33.73	19.05
DMCB20-20N	1-1/4	31.75	1-1/4	27.68	1-7/8	47.63	1-7/8	47.63	1-7/8	47.63	41.14	85.97	47.75	108.07	69.85	41.67	19.05
DMCB24-24N	1-1/2	38.10	1-1/2	34.03	2-1/4	57.15	2-1/4	57.15	2-1/4	57.15	50.03	93.03	49.27	120.21	76.45	49.61	19.05
DMCB32-32N	2	50.80	2	45.97	2-3/4	69.85	2-3/4	69.85	3	76.20	67.56	107.29	56.38	144.62	93.71	16.27	19.05

45° Male Elbow **DLBM**

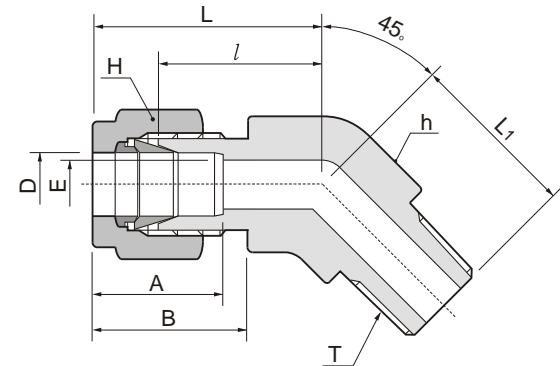

Connects fractional tube to female NPT thread

Part No.	Tube O.D. D		T (NPT)	E Min.	Width across flat				A	B	l	L	L1
	in	mm			h	H							
DLBM 4-2N	1/4	6.35	1/8	4.82	1/2	12.70	9/16	14.28	15.24	17.78	17.27	24.63	16.51
DLBM 4-4N	1/4	6.35	1/4	4.82	1/2	12.70	9/16	14.28	15.24	17.78	17.27	24.63	21.08
DLBM 6-2N	3/8	9.52	1/8	4.82	5/8	15.87	11/16	17.46	16.76	19.30	20.57	27.94	18.28
DLBM 6-4N	3/8	9.52	1/4	7.11	5/8	15.87	11/16	17.46	16.76	19.30	20.57	27.94	22.86
DLBM 6-6N	3/8	9.52	3/8	7.11	13/16	20.64	11/16	17.46	16.76	19.30	21.84	29.21	24.13
DLBM 8-6N	1/2	12.70	3/8	9.65	13/16	20.64	7/8	22.22	22.86	21.84	21.84	32.00	24.13
DLBM 8-8N	1/2	12.70	1/2	10.41	13/16	20.64	7/8	22.22	22.86	21.84	21.84	32.00	28.95
DLBM 12-12N	3/4	19.05	3/4	15.74	1-1/8	28.58	1-1/8	28.58	24.38	21.84	23.87	34.03	30.98
DLBM 16-16N	1	25.40	1	22.35	1-3/8	34.93	1-1/2	38.10	31.24	26.41	28.19	40.38	37.84

A, B & L are approximate figures in finger-tight.

All dimensions are in millimeters unless otherwise specified and only for reference subject to change.

Male Elbow DLM

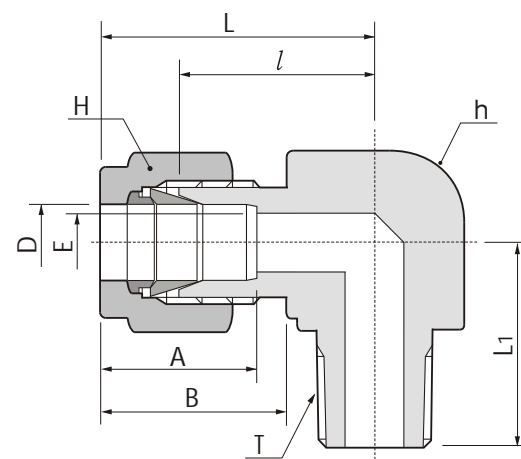

Connects fractional tube to female NPT thread

Part No.	Tube O.D.		T (NPT)	E Min.	Width across flat				A	B	l	L	L1
	D				h	H							
	in	mm				in	mm						
DLM 1-1N	1/16	1.59	1/16	1.27	7/16	11.11	5/16	7.93	8.63	10.92	15.24	19.05	17.78
DLM 1-2N	1/16	1.59	1/8	1.27	7/16	11.11	5/16	7.93	8.63	10.92	15.24	19.05	17.78
DLM 2-2N	1/8	3.17	1/8	2.28	1/2	12.70	7/16	11.11	12.70	15.24	18.30	24.91	18.90
DLM 2-4N	1/8	3.17	1/4	2.28	1/2	12.70	7/16	11.11	12.70	15.24	18.30	24.91	23.36
DLM 3-2N	3/16	4.76	1/8	3.04	1/2	12.70	1/2	12.70	13.71	16.00	18.79	25.40	18.79
DLM 3-4N	3/16	4.76	1/4	3.04	1/2	12.70	1/2	12.70	13.71	16.00	18.79	25.40	23.36
DLM 4-1N	1/4	6.35	1/16	3.04	1/2	12.70	9/16	14.28	15.24	17.78	19.55	26.90	18.79
DLM 4-2N	1/4	6.35	1/8	4.82	1/2	12.70	9/16	14.28	15.24	17.78	19.10	26.47	19.10
DLM 4-4N	1/4	6.35	1/4	4.82	1/2	12.70	9/16	14.28	15.24	17.78	19.81	27.18	23.87
DLM 4-6N	1/4	6.35	3/8	4.82	11/16	17.46	9/16	14.28	15.24	17.78	22.35	29.71	26.20
DLM 4-8N	1/4	6.35	1/2	4.82	13/16	20.64	9/16	14.28	15.24	17.78	24.60	31.97	33.02
DLM 5-2N	5/16	7.93	1/8	4.82	9/16	14.28	5/8	15.87	16.25	18.54	21.33	28.70	19.81
DLM 5-4N	5/16	7.93	1/4	6.35	9/16	14.28	5/8	15.87	16.25	18.54	21.33	29.77	24.50
DLM 5-6N	5/16	7.93	3/8	6.35	11/16	17.46	5/8	15.87	16.25	18.54	23.11	30.48	26.20
DLM 6-2N	3/8	9.52	1/8	4.82	5/8	15.87	11/16	17.46	16.76	19.30	23.11	30.48	20.60
DLM 6-4N	3/8	9.52	1/4	7.11	5/8	15.87	11/16	17.46	16.76	19.30	23.11	30.48	25.40
DLM 6-6N	3/8	9.52	3/8	7.11	11/16	17.46	11/16	17.46	16.76	19.30	23.87	31.24	26.20
DLM 6-8N	3/8	9.52	1/2	7.11	13/16	20.64	11/16	17.46	16.76	19.30	25.90	31.42	33.02
DLM 6-12N	3/8	9.52	3/4	7.11	1-1/16	26.98	11/16	17.46	16.76	19.30	29.71	37.08	36.83
DLM 8-4N	1/2	12.70	1/4	7.11	13/16	20.64	7/8	22.22	22.86	21.84	25.90	36.06	28.30
DLM 8-6N	1/2	12.70	3/8	9.65	13/16	20.64	7/8	22.22	22.86	21.84	25.90	36.06	28.30
DLM 8-8N	1/2	12.70	1/2	10.41	13/16	20.64	7/8	22.22	22.86	21.84	25.90	36.06	33.02
DLM 8-12N	1/2	12.70	3/4	10.41	1-1/16	26.98	7/8	22.22	22.86	21.84	29.71	39.87	36.83
DLM 10-6N	5/8	15.87	3/8	9.65	15/16	23.81	1	25.40	24.38	21.84	28.00	37.06	30.22
DLM 10-8N	5/8	15.87	1/2	11.93	15/16	23.81	1	25.40	24.38	21.84	28.00	37.06	35.10
DLM 10-12N	5/8	15.87	3/4	12.70	1-1/16	26.98	1	25.40	24.38	21.84	29.71	39.87	36.83
DLM 12-8N	3/4	19.05	1/2	11.93	1-1/16	26.98	1-1/8	28.57	24.38	21.84	29.71	39.87	37.00
DLM 12-12N	3/4	19.05	3/4	15.74	1-1/16	26.98	1-1/8	28.57	24.38	21.84	29.71	39.87	36.83
DLM 14-12N	7/8	22.22	3/4	15.74	1-1/4	31.75	1-1/4	31.75	25.90	21.84	34.54	44.70	41.65
DLM 16-12N	1	25.40	3/4	15.74	1-27-64	36.00	1-1/2	38.10	31.24	26.41	36.83	49.02	42.20
DLM 16-16N	1	25.40	1	22.35	1-27-64	36.00	1-1/2	38.10	31.24	26.41	36.83	49.02	46.70
DLM 20-20N	1-1/4	31.75	1-1/4	27.68	1-11/16	42.86	1-7/8	47.63	41.14	38.86	44.50	66.54	47.75
DLM 24-24N	1-1/2	38.10	1-1/2	34.03	2	50.80	2-1/4	57.15	50.03	45.21	50.80	77.97	60.45
DLM 32-32N	2	50.80	2	45.97	2-3/4	69.85	3	76.20	62.73	63.73	69.80	107.18	70.61

Male Elbow DLM

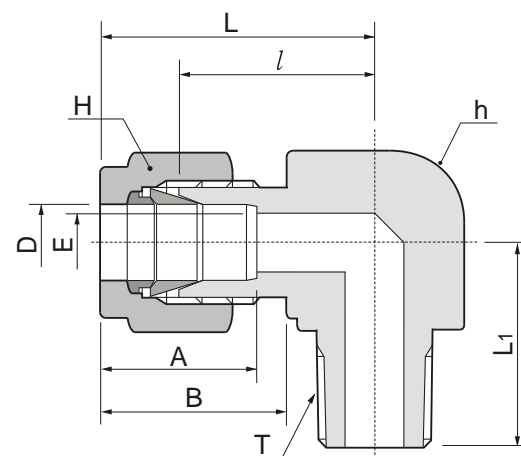

Connects metric tube to female ISO tapered thread

Part No.	Tube O.D. D	T R(PT)	E Min.	Width across flat		A	B	l	L	L1
				h	H					
DLM 3M-2R	3	1/8	2.4	12.7	12	12.9	15.3	17.0	23.6	17.8
DLM 3M-4R	3	1/4	2.4	12.7	12	12.9	15.3	18.0	24.6	23.4
DLM 4M-2R	4	1/8	2.4	12.7	12	13.7	16.1	18.8	25.4	18.8
DLM 4M-4R	4	1/4	2.4	12.7	12	13.7	16.1	18.8	25.4	23.4
DLM 6M-2R	6	1/8	4.8	12.7	14	15.3	17.7	19.6	27.0	18.8
DLM 6M-4R	6	1/4	4.8	12.7	14	15.3	17.7	19.6	27.0	23.4
DLM 6M-6R	6	3/8	4.8	17.5	14	15.3	17.7	22.4	29.8	26.2
DLM 6M-8R	6	1/2	4.8	20.6	14	15.3	17.7	24.4	31.8	33.0
DLM 8M-2R	8	1/8	4.8	14.3	16	16.2	18.6	21.3	28.8	19.8
DLM 8M-4R	8	1/4	6.4	14.3	16	16.2	18.6	21.3	28.8	24.4
DLM 8M-6R	8	3/8	6.4	17.5	16	16.2	18.6	23.1	30.6	26.2
DLM 8M-8R	8	1/2	6.4	20.6	16	16.2	18.6	25.1	32.6	33.0
DLM 10M-2R	10	1/8	4.8	17.5	19	17.2	19.5	23.9	31.5	23.6
DLM 10M-4R	10	1/4	7.1	17.5	19	17.2	19.5	23.9	31.5	26.2
DLM 10M-6R	10	3/8	7.9	17.5	19	17.2	19.5	23.9	31.5	26.2
DLM 10M-8R	10	1/2	7.9	20.6	19	17.2	19.5	25.9	33.5	33.0
DLM 12M-2R	12	1/8	4.8	20.6	22	22.8	22.0	25.9	36.0	23.6
DLM 12M-4R	12	1/4	7.1	20.6	22	22.8	22.0	25.9	36.0	28.2
DLM 12M-6R	12	3/8	9.5	20.6	22	22.8	22.0	25.9	36.0	28.2
DLM 12M-8R	12	1/2	9.5	20.6	22	22.8	22.0	25.9	36.0	33.0
DLM 12M-12R	12	3/4	9.5	27.0	22	22.8	22.0	29.7	39.8	36.8
DLM 16M-6R	16	3/8	9.5	25.4	25	24.4	22.0	27.9	38.0	30.2
DLM 16M-8R	16	1/2	11.9	25.4	25	24.4	22.0	27.9	38.0	35.1
DLM 16M-12R	16	3/4	12.7	27.0	25	24.4	22.0	29.7	39.8	36.8
DLM 18M-8R	18	1/2	11.9	27.0	30	24.4	22.0	29.7	39.8	36.8
DLM 18M-12R	18	3/4	15.1	27.0	30	24.4	22.0	29.7	39.8	36.8
DLM 20M-8R	20	1/2	11.9	31.8	32	26.0	22.0	34.5	44.6	41.7
DLM 20M-12R	20	3/4	15.9	31.8	32	26.0	22.0	34.5	44.6	41.7
DLM 22M-12R	22	3/4	15.9	31.8	32	26.0	22.0	34.5	44.6	41.7
DLM 22M-16R	22	1	18.3	36.0	32	26.0	22.0	34.5	44.6	46.5
DLM 25M-12R	25	3/4	15.9	36.0	38	31.3	26.5	36.8	49.1	41.7
DLM 25M-16R	25	1	21.8	36.0	38	31.3	26.5	36.8	49.1	46.5

A, B & L are approximate figures in finger-tight.

Male Run Tee DTRM

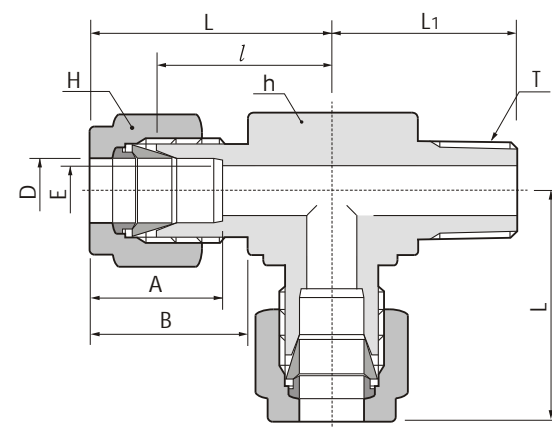

Connects fractional tube to female NPT thread

Part No.	Tube O.D.		T (NPT)	E Min.	Width across flat				A	B	l	L	L1
	in	mm			h	H	in	mm					
DTRM 1-1N	1/16	1.59	1/16	1.27	7/16	11.11	5/16	7.93	8.63	10.92	15.24	19.05	17.78
DTRM 1-2N	1/16	1.59	1/8	1.27	7/16	11.11	5/16	7.93	8.63	10.92	15.24	19.05	17.78
DTRM 2-2N	1/8	3.17	1/8	2.28	1/2	12.70	7/16	11.11	12.70	15.24	18.30	24.91	18.90
DTRM 2-4N	1/8	3.17	1/4	2.28	1/2	12.70	7/16	11.11	12.70	15.24	18.30	24.91	23.36
DTRM 3-2N	3/16	4.76	1/8	3.04	1/2	12.70	1/2	12.70	13.71	16.00	18.79	24.38	18.79
DTRM 3-4N	3/16	4.76	1/4	3.04	1/2	12.70	1/2	12.70	13.71	16.00	18.79	25.40	23.36
DTRM 4-1N	1/4	6.35	1/16	3.04	1/2	12.70	9/16	14.28	15.24	17.78	19.55	26.90	18.79
DTRM 4-2N	1/4	6.35	1/8	4.82	1/2	12.70	9/16	14.28	15.24	17.78	19.55	26.92	18.79
DTRM 4-4N	1/4	6.35	1/4	4.82	1/2	12.70	9/16	14.28	15.24	17.78	19.55	27.08	23.87
DTRM 4-6N	1/4	6.35	3/8	4.82	11/16	17.46	9/16	14.28	15.24	17.78	22.35	29.71	28.40
DTRM 4-8N	1/4	6.35	1/2	4.82	13/16	20.64	9/16	14.28	15.24	17.78	24.60	31.97	35.10
DTRM 5-2N	5/16	7.93	1/8	4.82	9/16	14.28	5/8	15.87	16.25	18.54	22.35	29.71	19.81
DTRM 5-4N	5/16	7.94	1/4	6.35	9/16	14.28	5/8	15.87	16.25	18.54	22.35	29.77	24.50
DTRM 5-6N	5/16	7.94	3/8	6.35	11/16	17.46	5/8	15.87	16.25	18.54	23.11	30.48	28.40
DTRM 6-4N	3/8	9.52	1/4	7.11	5/8	15.87	1/16	17.46	16.76	19.30	23.11	30.48	25.40
DTRM 6-6N	3/8	9.52	3/8	7.11	11/16	17.46	11/16	17.46	16.76	19.30	23.87	31.24	28.44
DTRM 6-8N	3/8	9.52	1/2	7.11	13/16	20.64	11/16	17.46	16.76	19.30	25.90	33.27	33.02
DTRM 6-12N	3/8	9.52	3/4	7.11	1-1/16	26.98	11/16	17.46	16.76	19.30	29.71	37.08	36.83
DTRM 8-4N	1/2	12.70	1/4	7.11	13/16	20.64	7/8	22.22	22.86	21.84	25.90	36.06	28.30
DTRM 8-6N	1/2	12.70	3/8	9.65	13/16	20.64	7/8	22.22	22.86	21.84	25.90	36.06	28.30
DTRM 8-8N	1/2	12.70	1/2	10.41	13/16	20.64	7/8	22.22	22.86	21.84	25.90	36.06	33.02
DTRM 8-12N	1/2	12.70	3/4	10.41	1-1/16	26.98	7/8	22.22	22.86	21.84	29.71	39.84	36.83
DTRM10-6N	5/8	15.87	3/8	9.65	15/16	23.81	1	25.40	24.38	21.84	27.90	38.10	29.40
DTRM10-8N	5/8	15.87	1/2	11.93	15/16	23.81	1	25.40	24.38	21.84	27.90	38.10	34.00
DTRM10-12N	5/8	15.87	3/4	12.70	1-1/16	26.98	1	25.40	24.38	21.84	29.71	39.87	36.83
DTRM12-8N	3/4	19.05	1/2	11.93	1-1/16	26.98	1-1/8	28.58	24.38	21.84	29.71	39.87	37.00
DTRM12-12N	3/4	19.05	3/4	15.74	1-1/16	26.98	1-1/8	28.58	24.38	21.84	29.71	39.81	36.83
DTRM14-12N	7/8	22.23	3/4	15.74	1-1/16	26.98	1-1/4	31.75	25.90	21.84	34.54	44.70	41.65
DTRM16-12N	1	25.40	3/4	15.74	1-1/4	31.75	1-1/2	38.10	31.24	26.41	36.83	49.02	42.20
DTRM16-16N	1	25.40	1	22.35	1-27/64	36.12	1-1/2	38.10	31.24	26.41	36.83	49.02	46.70
DTRM20-20N	1-1/4	31.75	1-1/4	27.68	1-27/64	36.12	1-7/8	47.63	41.14	38.86	44.50	66.54	47.75
DTRM24-24N	1-1/2	38.10	1-1/2	34.03	2	50.80	2-1/4	57.15	50.03	45.21	50.80	77.97	60.45
DTRM32-32N	2	50.80	2	45.97	2-3/4	69.85	3	76.20	67.56	62.73	69.80	107.18	70.61

Male Run Tee DTRM

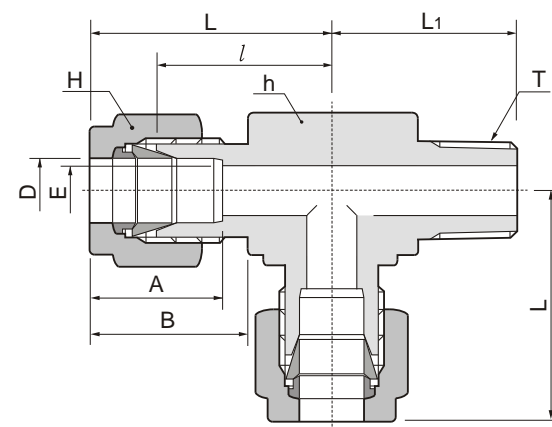

Connects metric tube to female ISO tapered thread

Part No.	Tube O.D. D	T R(PT)	E Min.	Width across flat		A	B	l	L	L1
				h	H					
DTRM 3M-2R	3	1/8	2.4	12.7	12	12.9	15.3	17.0	23.6	17.8
DTRM 3M-4R	3	1/4	2.4	12.7	12	12.9	15.3	18.0	24.6	23.4
DTRM 4M-2R	4	1/8	2.4	12.7	12	13.7	16.1	18.8	25.4	18.8
DTRM 4M-4R	4	1/4	2.4	12.7	12	13.7	16.1	18.8	25.4	23.4
DTRM 6M-2R	6	1/8	4.8	12.7	14	15.3	17.7	19.6	27.0	18.8
DTRM 6M-4R	6	1/4	4.8	14.2	14	15.3	17.7	19.6	27.0	23.4
DTRM 6M-6R	6	3/8	4.8	17.5	14	15.3	17.7	22.4	29.8	26.2
DTRM 6M-8R	6	1/2	4.8	20.6	14	15.3	17.7	24.4	31.8	33.0
DTRM 8M-2R	8	1/8	4.8	14.3	16	16.2	18.6	21.3	28.8	19.8
DTRM 8M-4R	8	1/4	6.4	14.3	16	16.2	18.6	21.3	28.8	24.4
DTRM 8M-6R	8	3/8	6.4	17.5	16	16.2	18.6	23.1	30.6	26.2
DTRM 8M-8R	8	1/2	6.4	20.6	16	16.2	18.6	25.1	32.6	33.0
DTRM 10M-2R	10	1/8	4.8	17.5	19	17.2	19.5	23.9	31.5	23.6
DTRM 10M-4R	10	1/4	7.1	17.5	19	17.2	19.5	23.9	31.5	26.2
DTRM 10M-6R	10	3/8	7.9	17.5	19	17.2	19.5	23.9	31.5	26.2
DTRM 10M-8R	10	1/2	7.9	20.6	19	17.2	19.5	25.9	33.5	33.0
DTRM 12M-2R	12	1/8	4.8	20.6	22	22.8	22.0	25.9	36.0	23.6
DTRM 12M-4R	12	1/4	7.1	20.6	22	22.8	22.0	25.9	36.0	28.2
DTRM 12M-6R	12	3/8	9.5	20.6	22	22.8	22.0	25.9	36.0	28.2
DTRM 12M-8R	12	1/2	9.5	20.6	22	22.8	22.0	25.9	36.0	33.0
DTRM 12M-12R	12	3/4	9.5	27.0	22	22.8	22.0	29.7	39.8	36.8
DTRM 16M-6R	16	3/8	9.5	25.4	25	24.4	22.0	27.9	38.0	30.2
DTRM 16M-8R	16	1/2	11.9	25.4	25	24.4	22.0	27.9	38.0	35.1
DTRM 16M-12R	16	3/4	12.7	27.0	25	24.4	22.0	29.7	39.8	36.8
DTRM 18M-8R	18	1/2	11.9	27.0	30	24.4	22.0	29.7	39.8	36.8
DTRM 18M-12R	18	3/4	15.1	27.0	30	24.4	22.0	29.7	39.8	36.8
DTRM 20M-8R	20	1/2	11.9	31.8	32	26.0	22.0	34.5	44.6	41.7
DTRM 20M-12R	20	3/4	15.9	31.8	32	26.0	22.0	34.5	44.6	41.7
DTRM 22M-12R	22	3/4	15.9	31.8	32	26.0	22.0	34.5	44.6	41.7
DTRM 22M-16R	22	1	18.3	36.0	32	26.0	22.0	34.5	44.6	46.5
DTRM 25M-12R	25	3/4	15.9	36.0	38	31.3	26.5	36.8	49.1	41.7
DTRM 25M-16R	25	1	21.8	36.0	38	31.3	26.5	36.8	49.1	46.5

A, B & L are approximate figures in finger-tight.

Male Branch Tee DTBM

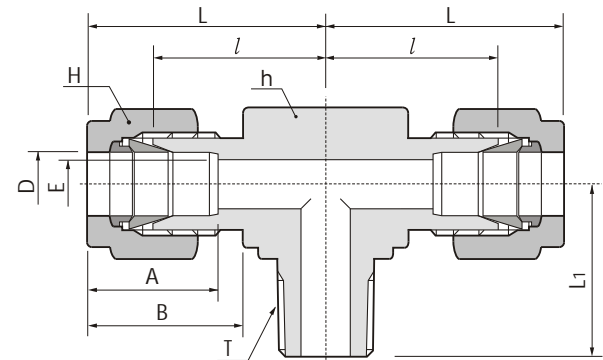

Connects fractional tube to female NPT thread

Part No.	Tube O.D.		T (NPT)	E Min.	Width across flat				A	B	l	L	L1
	in	mm			h	H	in	mm					
DTBM 1-1N	1/16	1.59	1/16	1.27	7/16	11.11	5/16	7.93	8.63	10.92	15.24	19.05	17.78
DTBM 1-2N	1/16	1.59	1/8	1.27	7/16	11.11	5/16	7.93	8.63	10.92	15.24	19.05	17.78
DTBM 2-2N	1/8	3.17	1/8	2.28	1/2	12.70	7/16	11.11	12.70	15.24	18.30	24.91	18.90
DTBM 2-4N	1/8	3.17	1/4	2.28	1/2	12.70	7/16	11.11	12.70	15.24	18.30	24.91	23.36
DTBM 3-2N	3/16	4.76	1/8	3.04	1/2	12.70	1/2	12.70	13.71	16.00	18.79	24.38	18.79
DTBM 3-4N	3/16	4.76	1/4	3.04	1/2	12.70	1/2	12.70	13.71	16.00	18.79	25.40	23.36
DTBM 4-1N	1/4	6.35	1/16	3.04	1/2	12.70	9/16	14.28	15.24	17.78	19.55	26.90	18.79
DTBM 4-2N	1/4	6.35	1/8	4.82	1/2	12.70	9/16	14.28	15.24	17.78	19.55	26.92	19.10
DTBM 4-4N	1/4	6.35	1/4	4.82	1/2	12.70	9/16	14.28	15.24	17.78	19.55	27.08	23.87
DTBM 4-6N	1/4	6.35	3/8	4.82	11/16	17.46	9/16	14.28	15.24	17.78	22.35	29.71	28.40
DTBM 4-8N	1/4	6.35	1/2	4.82	13/16	20.64	9/16	14.28	15.24	17.78	24.60	31.97	35.10
DTBM 5-2N	5/16	7.93	1/8	4.82	9/16	14.28	5/8	15.87	16.25	18.54	22.35	29.71	19.81
DTBM 5-4N	5/16	7.93	1/4	6.35	9/16	14.28	5/8	15.87	16.25	18.54	22.35	29.77	24.50
DTBM 5-6N	5/16	7.93	3/8	6.35	11/16	17.46	5/8	15.87	16.25	18.54	23.11	30.48	28.40
DTBM 6-4N	3/8	9.52	1/4	7.11	5/8	15.87	11/16	17.46	16.76	19.30	23.11	30.48	25.40
DTBM 6-6N	3/8	9.52	3/8	7.11	11/16	17.46	11/16	17.46	16.76	19.30	23.87	31.24	28.44
DTBM 6-8N	3/8	9.52	1/2	7.11	13/16	20.64	11/16	17.46	16.76	19.30	25.90	33.27	33.02
DTBM 6-12N	3/8	9.52	3/4	7.11	1-1/16	26.98	11/16	17.46	16.76	19.30	29.71	37.08	36.83
DTBM 8-4N	1/2	12.70	1/4	7.11	13/16	20.64	7/8	22.22	22.86	21.84	25.90	36.06	28.30
DTBM 8-6N	1/2	12.70	3/8	10.41	13/16	20.64	7/8	22.22	22.86	21.84	25.90	36.06	28.30
DTBM 8-8N	1/2	12.70	1/2	10.41	13/16	20.64	7/8	22.22	22.86	21.84	25.90	36.06	33.02
DTBM 8-12N	1/2	12.70	3/4	10.41	1-1/16	26.98	7/8	22.22	22.86	21.84	29.71	39.87	36.83
DTBM 10-6N	5/8	15.87	3/8	9.65	15/16	23.81	1	25.40	24.38	21.84	27.90	38.10	29.40
DTBM 10-8N	5/8	15.87	1/2	11.93	15/16	23.81	1	25.40	24.38	21.84	27.90	38.10	34.00
DTBM 10-12N	5/8	15.87	3/4	12.70	1-1/16	26.98	1	25.40	24.38	21.84	29.71	39.87	36.83
DTBM 12-8N	3/4	19.05	1/2	11.93	1-1/16	26.98	1-1/8	28.58	24.38	21.84	29.71	39.87	37.00
DTBM 12-12N	3/4	19.05	3/4	15.74	1-1/16	26.98	1-1/8	28.58	24.38	21.84	29.71	39.87	36.83
DTBM 14-12N	7/8	22.22	3/4	15.74	1-1/16	26.98	1-1/4	31.75	25.90	21.84	34.54	44.70	41.65
DTBM 16-12N	1	25.40	3/4	15.74	1-1/4	31.75	1-1/2	38.10	31.24	26.41	36.83	49.02	42.20
DTBM 16-16N	1	25.40	1	22.35	1-27/64	36.12	1-1/2	38.10	31.24	26.41	36.83	49.02	46.70
DTBM 20-20N	1-1/4	31.75	1-1/4	27.68	1-27/64	36.12	1-7/8	47.63	41.14	38.86	44.50	66.54	47.75
DTBM 24-24N	1-1/2	38.10	1-1/2	34.03	2	50.80	2-1/4	57.15	50.03	45.21	50.80	77.97	60.45
DTBM 32-32N	2	50.80	2	45.97	2-3/4	69.85	3	76.20	67.56	62.73	69.80	107.18	70.61

Male Branch Tee DTBM

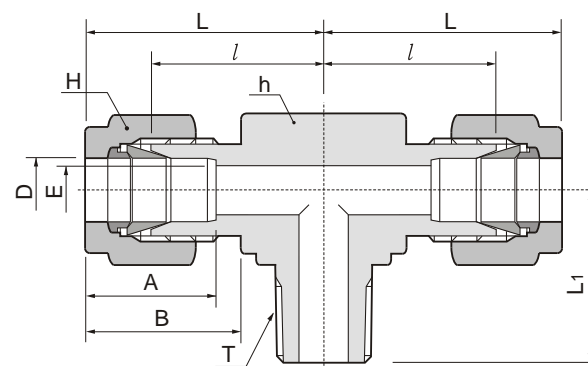

Connects metric tube to female ISO tapered thread

Part No.	Tube O.D. D	T R(PT)	E Min.	Width across flat		A	B	l	L	L1
				h	H					
DTBM 3M-2R	3	1/8	2.4	12.7	12	12.9	15.3	17.0	23.6	17.8
DTBM 3M-4R	3	1/4	2.4	12.7	12	12.9	15.3	18.0	24.6	23.4
DTBM 4M-2R	4	1/8	2.4	12.7	12	13.7	16.1	18.8	25.4	18.8
DTBM 4M-4R	4	1/4	2.4	12.7	12	13.7	16.1	18.8	25.4	23.4
DTBM 6M-2R	6	1/8	4.8	12.7	14	15.3	17.7	19.6	27.0	18.8
DTBM 6M-4R	6	1/4	4.8	14.2	14	15.3	17.7	19.6	27.0	23.4
DTBM 6M-6R	6	3/8	4.8	17.5	14	15.3	17.7	22.4	29.8	26.2
DTBM 6M-8R	6	1/2	4.8	20.6	14	15.3	17.7	24.4	31.8	33.0
DTBM 8M-2R	8	1/8	4.8	14.3	16	16.2	18.6	21.3	28.8	19.8
DTBM 8M-4R	8	1/4	6.4	14.3	16	16.2	18.6	21.3	28.8	24.4
DTBM 8M-6R	8	3/8	6.4	17.5	16	16.2	18.6	23.1	30.6	26.2
DTBM 8M-8R	8	1/2	6.4	20.6	16	16.2	18.6	25.1	32.6	33.0
DTBM 10M-2R	10	1/8	4.8	17.5	19	17.2	19.5	23.9	31.5	23.6
DTBM 10M-4R	10	1/4	7.1	17.5	19	17.2	19.5	23.9	31.5	26.2
DTBM 10M-6R	10	3/8	7.9	17.5	19	17.2	19.5	23.9	31.5	26.2
DTBM 10M-8R	10	1/2	7.9	20.6	19	17.2	19.5	25.9	33.5	33.0
DTBM 12M-2R	12	1/8	4.8	20.6	22	22.8	22.0	25.9	36.0	23.6
DTBM 12M-4R	12	1/4	7.1	20.6	22	22.8	22.0	25.9	36.0	28.2
DTBM 12M-6R	12	3/8	9.5	20.6	22	22.8	22.0	25.9	36.0	28.2
DTBM 12M-8R	12	1/2	9.5	20.6	22	22.8	22.0	25.9	36.0	33.0
DTBM 12M-12R	12	3/4	9.5	27.0	22	22.8	22.0	29.7	39.8	36.8
DTBM 16M-6R	16	3/8	9.5	25.4	25	24.4	22.0	27.9	38.0	30.2
DTBM 16M-8R	16	1/2	11.9	25.4	25	24.4	22.0	27.9	38.0	35.1
DTBM 16M-12R	16	3/4	12.7	27.0	25	24.4	22.0	29.7	39.8	36.8
DTBM 18M-8R	18	1/2	11.9	27.0	30	24.4	22.0	29.7	39.8	36.8
DTBM 18M-12R	18	3/4	15.1	27.0	30	24.4	22.0	29.7	39.8	36.8
DTBM 20M-8R	20	1/2	11.9	31.8	32	26.0	22.0	34.5	44.6	41.7
DTBM 20M-12R	20	3/4	15.9	31.8	32	26.0	22.0	34.5	44.6	41.7
DTBM 22M-12R	22	3/4	15.9	31.8	32	26.0	22.0	34.5	44.6	41.7
DTBM 22M-16R	22	1	18.3	36.0	32	26.0	22.0	34.5	44.6	46.5
DTBM 25M-12R	25	3/4	15.9	36.0	38	31.3	26.5	36.8	49.1	41.7
DTBM 25M-16R	25	1	21.8	36.0	38	31.3	26.5	36.8	49.1	46.5

A, B & L are approximate figures in finger-tight.

Female Connector DCF

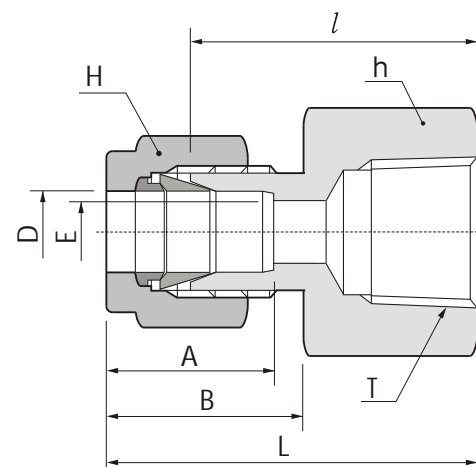
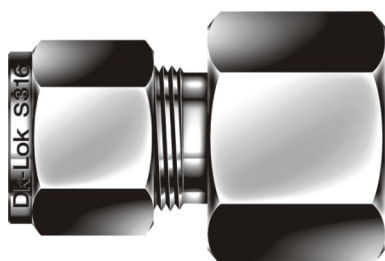

Connects fractional tube to male NPT thread

Part No.	Tube O.D. D		T (NPT)	E Min.	Width across flat				A	B	l	L
	in	mm			h	H	h	H				
DCF 1-1N	1/16	1.59	1/16	1.27	7/16	11.11	5/16	7.93	8.63	10.92	19.81	23.62
DCF 1-2N	1/16	1.59	1/8	1.27	9/16	14.28	5/16	7.93	8.63	10.92	20.57	24.38
DCF 2-2N	1/8	3.17	1/8	2.28	9/16	14.28	7/16	11.11	12.70	15.24	22.09	28.70
DCF 2-4N	1/8	3.17	1/4	2.28	3/4	19.05	7/16	11.11	12.70	15.24	26.92	33.52
DCF 3-2N	3/16	4.76	1/8	3.04	9/16	14.28	1/2	12.70	13.71	16.00	23.11	29.71
DCF 4-2N	1/4	6.35	1/8	4.82	9/16	14.28	9/16	14.28	15.24	17.78	23.87	31.24
DCF 4-4N	1/4	6.35	1/4	4.82	3/4	19.05	9/16	14.28	15.24	17.78	28.44	35.81
DCF 4-6N	1/4	6.35	3/8	4.82	7/8	22.22	9/16	14.28	15.24	17.78	30.22	37.59
DCF 4-8N	1/4	6.35	1/2	4.82	1-1/16	26.98	9/16	14.28	15.24	17.78	35.05	42.41
DCF 5-2N	5/16	7.93	1/8	6.35	9/16	14.28	5/8	15.87	16.25	18.54	24.63	32.00
DCF 5-4N	5/16	7.93	1/4	6.35	3/4	19.05	5/8	15.87	16.25	18.54	29.46	36.83
DCF 6-2N	3/8	9.52	1/8	7.11	5/8	15.87	11/16	17.46	16.76	19.30	25.40	32.76
DCF 6-4N	3/8	9.52	1/4	7.11	3/4	19.05	11/16	17.46	16.76	19.30	30.22	37.59
DCF 6-6N	3/8	9.52	3/8	7.11	7/8	22.22	11/16	17.46	16.76	19.30	31.75	39.11
DCF 6-8N	3/8	9.52	1/2	7.11	1-1/16	26.98	11/16	17.46	16.76	19.30	36.57	43.94
DCF 6-12N	3/8	9.52	3/4	7.11	1-5/16	33.33	11/16	17.46	16.76	19.30	40.38	47.75
DCF 8-4N	1/2	12.70	1/4	10.41	1-3/16	20.64	7/8	22.22	22.86	21.84	30.22	40.38
DCF 8-6N	1/2	12.70	3/8	10.41	7/8	22.22	7/8	22.22	22.86	21.84	31.75	41.91
DCF 8-8N	1/2	12.70	1/2	10.41	1-1/16	26.98	7/8	22.22	22.86	21.84	36.57	46.73
DCF 8-12N	1/2	12.70	3/4	10.41	1-5/16	33.33	7/8	22.22	22.86	21.84	38.10	48.26
DCF10-6N	5/8	15.87	3/8	12.70	15/16	23.81	1	25.40	24.38	21.84	31.75	41.91
DCF10-8N	5/8	15.87	1/2	12.70	1-1/16	26.98	1	25.40	24.38	21.84	36.57	46.73
DCF10-12N	5/8	15.87	3/4	12.70	1-5/16	33.33	1	25.40	24.38	21.84	38.10	48.26
DCF12-8N	3/4	19.05	1/2	15.74	1-1/16	26.98	1-1/8	28.58	24.38	21.84	36.57	46.73
DCF12-12N	3/4	19.05	3/4	15.74	1-5/16	33.33	1-1/8	28.58	24.38	21.84	38.10	48.26
DCF14-12N	7/8	22.22	3/4	18.28	1-5/16	33.33	1-1/4	31.75	25.90	21.84	39.62	49.78
DCF16-12N	1	25.40	3/4	22.35	1-3/8	34.92	1-1/2	38.10	31.24	26.41	41.14	53.34
DCF16-16N	1	25.40	1	22.35	1-5/8	41.27	1-1/2	38.10	31.24	26.41	50.03	62.23
DCF20-20N	1-1/4	31.75	1-1/4	27.68	2-1/8	53.98	1-7/8	47.63	41.14	38.86	52.57	74.67
DCF24-24N	1-1/2	38.10	1-1/2	34.03	2-3/8	60.33	2-1/4	57.15	50.03	45.21	56.13	83.31
DCF32-32N	2	50.80	2	45.97	2-1/8	73.03	3	76.20	67.56	62.73	64.26	101.60

Female Connector DCF

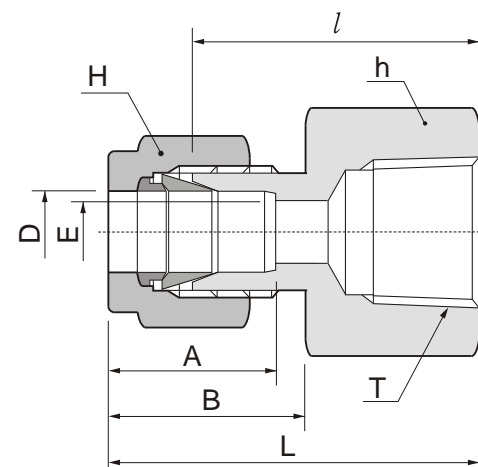
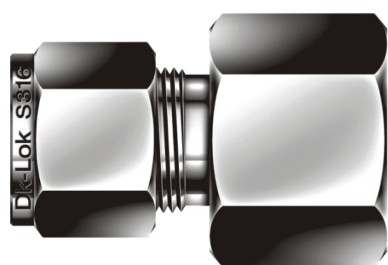

Connects metric tube to male ISO tapered thread

Part No.	Tube O.D. D	T R(PT)	E Min.	Width across flat		A	B	l	L
				h	H				
DCF 3M-2R	3	1/8	2.4	14	12	12.9	15.3	22.1	28.7
DCF 3M-4R	3	1/4	2.4	19	12	12.9	15.3	26.9	33.5
DCF 4M-2R	4	1/8	2.4	14	12	13.7	16.1	23.1	29.7
DCF 6M-2R	6	1/8	4.8	14	14	15.3	17.7	23.9	31.3
DCF 6M-4R	6	1/4	4.8	19	14	15.3	17.7	28.4	35.8
DCF 6M-6R	6	3/8	4.8	22	14	15.3	17.7	29.5	36.9
DCF 6M-8R	6	1/2	4.8	27	14	15.3	17.7	35.1	42.5
DCF 8M-2R	8	1/8	6.4	15	16	16.2	18.6	24.6	32.1
DCF 8M-4R	8	1/4	6.4	19	16	16.2	18.6	29.5	37.0
DCF 8M-6R	8	3/8	6.4	22	16	16.2	18.6	30.2	37.7
DCF 8M-8R	8	1/2	6.4	27	16	16.2	18.6	35.8	43.3
DCF 10M-2R	10	1/8	7.9	18	19	17.2	19.5	25.4	33.0
DCF 10M-4R	10	1/4	7.9	19	19	17.2	19.5	30.2	37.8
DCF 10M-6R	10	3/8	7.9	22	19	17.2	19.5	31.0	38.6
DCF 10M-8R	10	1/2	7.9	27	19	17.2	19.5	36.6	44.2
DCF 12M-2R	12	1/8	8.3	22	22	22.8	22.0	28.4	38.5
DCF 12M-4R	12	1/4	9.5	22	22	22.8	22.0	30.2	40.3
DCF 12M-6R	12	3/8	9.5	22	22	22.8	22.0	31.0	41.1
DCF 12M-8R	12	1/2	9.5	27	22	22.8	22.0	36.6	46.7
DCF 12M-12R	12	3/4	9.5	35	22	22.8	22.0	38.9	49.0
DCF 15M-8R	15	1/2	11.9	27	25	24.4	22.0	36.6	46.7
DCF 16M-8R	16	1/2	12.7	27	25	24.4	22.0	36.8	46.9
DCF 20M-8R	20	1/2	15.9	30	32	26.0	22.0	37.8	47.9
DCF 20M-12R	20	3/4	15.9	35	32	26.0	22.0	39.6	49.7
DCF 22M-12R	22	3/4	18.3	35	32	26.0	22.0	39.6	49.7
DCF 22M-16R	22	1	18.3	41	32	26.0	22.0	47.8	57.9
DCF 25M-12R	25	3/4	21.8	35	38	31.3	26.5	41.1	53.4
DCF 25M-16R	25	1	21.8	41	38	31.3	26.5	50.0	62.3

A, B & L are approximate figures in finger-tight.

Gauge Connector DCG

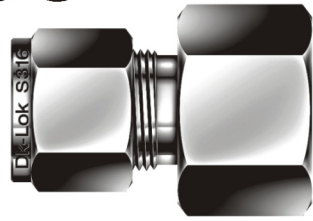

See page 23
for DGG gasket

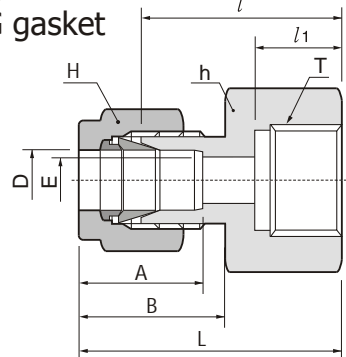

Connects metric tube to ISO parallel thread (gauge)

Part No.	Tube O.D.		T R(PF)	E Min.	Width across flat		A	B	l	l ₁	L
	D				h	H					
DCG 3M-4G	3		1/4	2.4	19	12	12.9	15.3	28.7	13	35.3
DCG 6M-4G	6		1/4	4.8	19	14	15.3	17.7	30.2	13	37.6
DCG 6M-6G	6		3/8	4.8	24	14	15.3	17.7	30.2	14	37.6
DCG 6M-8G	6		1/2	4.8	27	14	15.3	17.7	36.3	19	43.0
DCG 8M-4G	8		1/4	5.5	19	16	16.2	18.6	31.0	13	38.5
DCG 8M-6G	8		3/8	6.5	24	16	16.2	18.6	28.7	14	36.2
DCG 8M-8G	8		1/2	7.0	27	16	16.2	18.6	33.0	19	40.5
DCG 10M-4G	10		1/4	5.5	19	19	17.2	19.5	31.8	13	39.4
DCG 10M-6G	10		3/8	6.5	24	19	17.2	19.5	31.2	14	38.8
DCG 10M-8G	10		1/2	7.0	27	19	17.2	19.5	33.8	19	41.4
DCG 12M-4G	12		1/4	5.5	22	22	22.8	22.0	31.8	13	41.9
DCG 12M-6G	12		3/8	6.5	24	22	22.8	22.0	34.3	14	44.4
DCG 12M-8G	12		1/2	7.0	27	22	22.8	22.0	38.1	19	48.2
DCG 20M-8G	20		1/2	7.0	30	32	26.0	22.0	44.2	19	54.3
DCG 22M-8G	22		1/2	7.0	30	32	26.0	22.0	44.2	19	54.3

Connects fractional tube to ISO parallel thread (gauge)

Part No.	Tube O.D.		T G(PF)	E Min.	Width across flat				A	B	l	l ₁	L
	D				h	H							
	in	mm				in	mm						
DCG 4-2G	1/4	6.35	1/8	4.82	9/16	14.28	9/16	14.28	15.24	17.78	26.30	12.00	33.55
DCG 4-4G	1/4	6.35	1/4	4.82	3/4	19.05	9/16	14.28	15.24	17.78	30.22	13.00	37.59
DCG 4-6G	1/4	6.35	3/8	4.82	15/16	23.81	9/16	14.28	15.24	17.78	30.22	14.22	37.59
DCG 4-8G	1/4	6.35	1/2	4.82	1-1/16	26.98	9/16	14.28	15.24	17.78	30.07	18.80	43.43
DCG 5-4G	5/16	7.93	1/4	5.58	3/4	19.05	5/8	15.87	16.25	18.54	30.98	13.00	38.35
DCG 5-8G	5/16	7.93	1/2	7.11	1-1/16	26.98	5/8	15.87	16.25	18.54	33.02	18.80	40.38
DCG 6-4G	3/8	9.52	1/4	5.58	3/4	19.05	11/16	17.46	16.76	19.30	31.75	12.95	39.12
DCG 6-6G	3/8	9.52	3/8	6.60	15/16	23.81	11/16	17.46	16.76	19.30	31.24	14.22	38.61
DCG 6-8G	3/8	9.52	1/2	7.11	1-1/16	26.98	11/16	17.46	16.76	19.30	34.54	18.80	41.91
DCG 8-4G	1/2	12.70	1/4	5.50	7/8	22.22	7/8	22.22	22.86	21.84	31.80	13.00	41.95
DCG 8-6G	1/2	12.70	3/8	6.60	15/16	23.81	7/8	22.22	22.86	21.84	34.29	14.24	44.45
DCG 8-8G	1/2	12.70	1/2	7.11	1-1/16	26.98	7/8	22.22	22.86	21.84	38.10	18.80	48.26

Bulkhead Female Connector DCBF

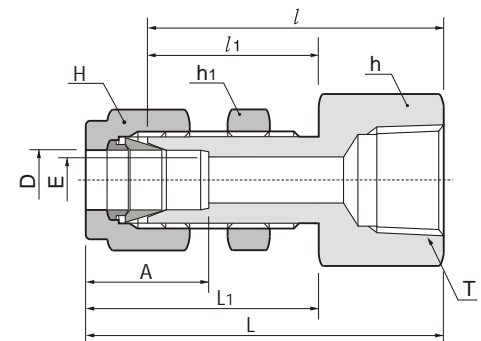
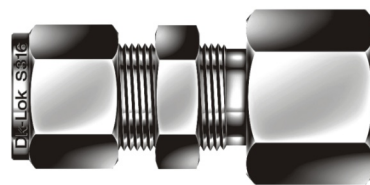

Connects fractional tube to male NPT thread

Part No.	Tube O.D.		T (NPT)	E Min.	Width across flat					A	l	l ₁	L	L ₁	Panel Hole Drill Size	Panel Max Thickness	
	D				h	h ₁		H									
	in	mm				in	mm		in								mm
DCBF 2-2N	1/8	3.17	1/8	2.28	9/16	14.28	1/2	12.70	7/16	11.11	12.70	38.10	24.63	44.70	31.24	8.33	12.70
DCBF 4-2N	1/4	6.35	1/8	4.82	5/8	15.87	5/8	15.87	9/16	14.28	15.24	39.62	26.16	46.99	33.52	11.50	10.16
DCBF 4-4N	1/4	6.35	1/4	4.82	3/4	19.05	5/8	15.87	9/16	14.28	15.24	44.45	26.16	51.81	33.52	11.50	10.16
DCBF 6-4N	3/8	9.52	1/4	7.11	3/4	19.05	3/4	19.05	11/16	17.46	16.76	47.75	29.46	55.11	36.83	14.68	11.17
DCBF 6-6N	3/8	9.52	3/8	7.11	7/8	22.22	3/4	19.05	11/16	17.46	16.76	49.41	29.46	56.77	36.83	14.68	11.17
DCBF 8-6N	1/2	12.70	3/8	10.41	15/16	23.81	15/16	23.81	7/8	22.22	22.86	51.56	31.75	61.72	41.91	19.44	12.70
DCBF 8-8N	1/2	12.70	1/2	10.41	1-1/16	26.98	15/16	23.81	7/8	22.22	22.86	56.38	31.75	66.54	41.91	19.44	12.70
DCBF12-12N	3/4	19.05	3/4	15.74	1-1/4	31.75	1-3/16	30.16	1-1/8	28.57	24.38	63.60	38.30	73.51	47.21	25.79	16.76
DCBF16-16N	1	25.40	1	22.35	1-5/8	41.27	1-5/8	41.27	1-1/2	38.10	31.24	81.04	45.21	93.23	57.40	33.73	19.05
DCBF20-20N	1-1/4	31.75	1-1/4	27.68	1-7/8	47.63	1-7/8	47.63	1-7/8	47.63	41.14	83.49	47.75	105.59	69.85	41.67	19.05
DCBF24-24N	1-1/2	38.10	1-1/2	34.03	1-1/4	57.15	2-1/4	57.15	2-1/4	57.15	50.03	87.39	49.27	114.57	76.45	49.61	19.05
DCBF32-32N	2	50.80	2	45.97	1-3/4	69.85	2-3/4	69.85	3	76.20	67.56	95.30	56.38	132.63	93.71	57.94	19.05

Connects metric tube to male NPT thread

Part No.	Tube O.D.		T (NPT)	E Min.	Width across flat			A	l	l ₁	L	L ₁	Panel Hole Drill Size	Panel Max Thickness
	D				h	h ₁	H							
DCBF 6M-2N	6		1/8	4.8	15.8	15.8	14	15.3	39.6	26.2	46.90	35.00	11.5	10.2
DCBF 6M-4N	6		1/4	4.8	19.0	16.0	14	15.3	44.4	26.2	51.80	33.60	11.5	10.2
DCBF 8M-4N	8		1/4	6.3	19.0	17.4	16	16.2	46.7	28.6	53.85	35.55	13.1	11.2
DCBF 12M-8N	12		1/2	9.5	27.0	24.0	22	22.8	56.4	31.8	66.50	41.90	19.5	12.7

Female Elbow DLF

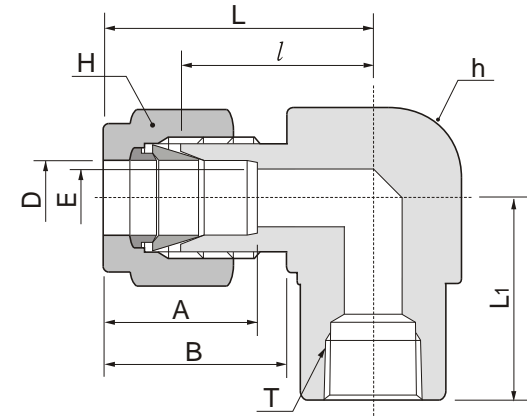
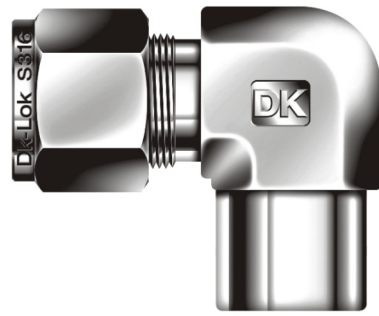

Connects fractional tube to male NPT thread

Part No.	Tube O.D. D		T (NPT)	E Min.	Width across flat				A	B	l	L	L1
	in	mm			h		H						
					in	mm	in	mm					
DLF 2-2N	1/8	3.17	1/8	2.28	1/2	12.70	7/16	11.11	12.70	15.24	18.03	24.63	19.05
DLF 2-4N	1/8	3.17	1/4	2.28	11/16	17.46	7/16	11.11	12.70	15.24	20.82	27.43	22.35
DLF 3-2N	3/16	4.76	1/8	3.04	1/2	12.70	1/2	12.70	13.71	16.00	18.79	25.40	19.05
DLF 4-2N	1/4	6.35	1/8	4.82	1/2	12.70	9/16	14.28	15.24	17.78	19.55	26.92	19.05
DLE 4-4N	1/4	6.35	1/4	4.82	11/16	17.46	9/16	14.28	15.24	17.78	22.35	29.71	22.35
DLF 4-6N	1/4	6.35	3/8	4.82	13/16	20.64	9/16	14.28	15.24	17.78	24.38	31.75	22.35
DLF 4-8N	1/4	6.35	1/2	4.82	1	25.40	9/16	14.28	15.24	17.78	27.17	34.54	28.44
DLF 5-2N	5/16	7.93	1/8	6.35	9/16	14.28	5/8	15.87	16.25	18.54	21.33	28.70	19.05
DLF 5-4N	5/16	7.93	1/4	6.35	11/16	17.46	5/8	15.87	16.25	18.54	23.11	30.48	22.35
DLF 6-2N	3/8	9.52	1/8	7.11	5/8	15.87	11/16	17.46	16.76	19.30	23.11	30.48	19.05
DLF 6-4N	3/8	9.52	1/4	7.11	11/16	17.46	11/16	17.46	16.76	19.30	23.87	31.24	22.35
DLF 6-6N	3/8	9.52	3/8	7.11	13/16	20.64	11/16	17.46	16.76	19.30	25.90	33.27	22.35
DLF 6-8N	3/8	9.52	1/2	7.11	1	25.40	11/16	17.46	16.76	19.30	28.70	36.06	28.44
DLF 8-4N	1/2	12.70	1/4	10.41	13/16	20.64	7/8	22.22	22.86	21.84	25.90	36.06	22.35
DLF 8-6N	1/2	12.70	3/8	10.41	13/16	20.64	7/8	22.22	22.86	21.84	25.90	36.06	22.35
DLF 8-8N	1/2	12.70	1/2	10.41	1	25.40	7/8	22.22	22.86	21.84	28.70	38.86	28.44
DLF 10-6N	5/8	15.87	3/8	12.70	15/16	23.81	1	25.40	24.38	21.84	27.94	38.10	22.35
DLF 10-8N	5/8	15.87	1/2	12.70	1	25.40	1	25.40	24.38	21.84	29.71	39.87	28.44
DLF 12-8N	3/4	19.05	1/2	15.74	1-1/16	26.98	1-1/8	28.58	24.38	21.84	29.71	39.87	28.44
DLF 12-12N	3/4	19.05	3/4	15.74	1-1/4	31.75	1-1/8	28.58	24.38	21.84	34.54	44.70	31.75
DLF 14-12N	7/8	22.22	3/4	18.28	1-1/4	31.75	1-1/4	31.75	25.90	21.84	34.54	44.70	31.75
DLF 16-12N	1	25.40	3/4	22.35	1-27/64	36.00	1-1/2	38.10	31.24	26.41	36.83	49.02	31.75
DLF 16-16N	1	25.40	1	22.35	1-11/16	42.86	1-1/2	38.10	31.24	26.41	41.40	50.29	38.10

Connects metric tube to male NPT thread

Part No.	Tube O.D. D	T (NPT)	E Min.	Width across flat		A	B	l	L	L1
				h	H					
DLF 6M-2N	6	1/8	4.8	12.70	14	15.3	17.7	19.6	27.0	19.00
DLF 6M-4N	6	1/4	4.8	17.46	14	15.3	17.7	22.4	29.8	22.40
DLF 6M-6N	6	3/8	4.8	20.64	14	15.3	17.7	24.4	31.7	22.40
DLF 6M-8N	6	1/2	4.8	25.40	14	15.3	17.7	27.2	34.6	28.40
DLF 8M-2N	8	1/8	6.4	15.87	16	16.2	18.6	23.1	29.9	19.00
DLF 8M-4N	8	1/4	6.4	17.46	16	16.2	18.6	23.1	30.6	22.40
DLF 8M-8N	8	1/2	6.4	25.40	16	16.2	18.6	28.0	35.2	28.40
DLF10M-2N	10	1/8	7.9	17.46	19	17.2	19.5	23.9	31.5	19.00
DLF10M-4N	10	1/4	7.9	17.46	19	17.2	19.5	25.9	33.5	22.35
DLF10M-6N	10	3/8	7.9	20.64	19	17.2	19.5	25.9	33.5	22.40
DLF10M-8N	10	1/2	7.9	25.40	19	17.2	19.5	28.7	36.1	28.40
DLF12M-4N	12	1/4	9.5	20.64	22	22.8	22.0	25.9	36.0	22.40
DLF12M-6N	12	3/8	9.5	20.64	22	22.8	22.0	25.9	36.2	22.35
DLF12M-8N	12	1/2	9.5	25.40	22	22.8	22.0	28.7	38.8	28.40
DLF16M-8N	16	1/2	12.7	26.98	25	24.4	22.0	29.7	39.5	28.40

A, B & L are approximate figures in finger-tight.

Female Run Tee DTRF

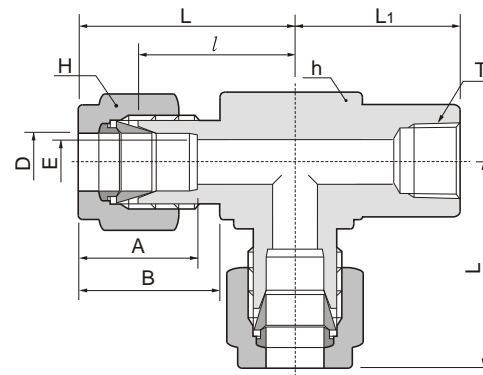

Connects fractional tube to male NPT thread

Part No.	Tube O D		T (NPT)	E Min.	Width across flat				A	B	l	L	L1
	D				h	H	A	B					
	in	mm											
DTRF 2-2N	1/8	3.17	1/8	2.28	1/2	12.70	7/16	11.11	12.70	15.24	18.03	24.63	19.05
DTRF 2-4N	1/8	3.17	1/4	2.28	11/16	17.46	7/16	11.11	12.70	15.24	20.82	27.43	22.35
DTRF 3-2N	3/16	4.76	1/8	3.04	1/2	12.70	1/2	12.70	13.71	16.00	18.79	25.40	19.05
DTRF 4-2N	1/4	6.35	1/8	4.82	1/2	12.70	9/16	14.28	15.24	17.78	19.55	26.92	19.05
DTRF 4-4N	1/4	6.35	1/4	4.82	11/16	17.46	9/16	14.28	15.24	17.78	22.86	29.71	22.35
DTRF 4-6N	1/4	6.35	3/8	4.82	13/16	20.64	9/16	14.28	15.24	17.78	24.38	31.75	22.35
DTRF 4-8N	1/4	6.35	1/2	4.82	1	25.40	9/16	14.28	15.24	17.78	27.17	34.54	28.44
DTRF 5-2N	5/16	7.94	1/8	6.35	9/16	14.28	5/8	15.87	16.25	18.54	21.33	28.70	19.05
DTRF 5-4N	5/16	7.94	1/4	6.35	11/16	17.46	5/8	15.87	16.25	18.54	23.11	30.48	22.35
DTRF 6-2N	3/8	9.52	1/8	7.11	5/8	15.87	11/16	17.46	16.76	19.30	23.11	30.48	19.05
DTRF 6-4N	3/8	9.52	1/4	7.11	11/16	17.46	11/16	17.46	16.76	19.30	23.87	31.24	22.35
DTRF 6-6N	3/8	9.52	3/8	6.35	13/16	20.64	11/16	17.46	16.76	19.30	25.90	33.27	22.35
DTRF 6-8N	3/8	9.52	1/2	7.11	1	25.40	11/16	17.46	16.76	19.30	28.70	36.06	28.44
DTRF 8-4N	1/2	12.70	1/4	10.41	13/16	20.64	7/8	22.22	22.86	21.84	25.90	36.06	22.35
DTRF 8-6N	1/2	12.70	3/8	10.41	13/16	20.64	7/8	22.22	22.86	21.84	25.90	36.06	22.35
DTRF 8-8N	1/2	12.70	1/2	10.41	1	25.40	7/8	22.22	22.86	21.84	29.71	39.87	28.44
DTRF10-6N	5/8	15.87	3/8	12.70	15/16	23.81	1	25.40	24.38	21.84	27.94	38.10	22.35
DTRF10-8N	5/8	15.87	1/2	12.70	1	25.40	1	25.40	24.38	21.84	28.70	38.86	28.44
DTRF12-8N	3/4	19.05	1/2	15.74	1-1/16	26.98	1-1/8	28.58	24.38	21.84	29.71	39.87	28.44
DTRF12-12N	3/4	19.05	3/4	15.74	1-1/4	31.75	1-1/8	28.58	24.38	21.84	34.54	44.70	31.75
DTRF14-12N	7/8	22.22	3/4	18.28	1-1/4	31.75	1-1/4	31.75	31.75	21.84	34.54	44.70	31.75
DTRF16-12N	1	25.40	3/4	22.35	1-27/64	36.12	1-1/2	38.10	38.10	26.41	36.83	49.02	31.75
DTRF16-16N	1	25.40	1	22.35	1-1/16	42.86	1-1/2	38.10	38.10	26.41	41.40	50.29	38.10

Connects metric tube to male NPT thread

Part No.	Tube O.D.	T (NPT)	E Min.	Width across flat		A	B	l	L	L1
	D			h	H					
DTRF 6M-2N	6	1/8	4.8	12.70	14	15.3	17.7	19.6	27.0	19.00
DTRF 6M-4N	6	1/4	4.8	17.46	14	15.3	17.7	22.4	29.8	22.40
DTRF 6M-6N	6	3/8	4.8	20.64	14	15.3	17.7	24.4	31.7	22.40
DTRF 6M-8N	6	1/2	4.8	25.40	14	15.3	17.7	27.2	34.5	28.40
DTRF 8M-2N	8	1/8	6.4	15.87	16	16.2	18.6	23.1	29.9	19.00
DTRF 8M-4N	8	1/4	6.4	17.46	16	16.2	18.6	23.1	30.6	22.40
DTRF 8M-6N	8	3/8	6.4	20.64	16	16.2	18.6	25.2	32.4	22.40
DTRF 8M-8N	8	1/2	6.4	25.40	16	16.2	18.6	28.0	35.2	28.40
DTRF10M-2N	10	1/8	7.9	20.64	19	17.2	19.5	23.9	31.5	19.00
DTRF10M-4N	10	1/4	7.9	20.64	19	17.2	19.5	25.9	33.6	22.40
DTRF10M-6N	10	3/8	7.9	20.64	19	17.2	19.5	25.9	33.6	22.40
DTRF10M-8N	10	1/2	7.9	25.40	19	17.2	19.5	26.2	33.6	28.40
DTRF12M-4N	12	1/4	9.5	20.64	22	22.8	22.0	25.9	36.0	22.40
DTRF12M-6N	12	3/8	9.5	20.64	22	22.8	22.0	25.9	36.0	22.40
DTRF12M-8N	12	1/2	9.5	25.40	22	22.8	22.0	29.7	40.0	28.40
DTRF16M-8N	16	1/2	12.7	25.40	25	24.4	22.0	29.7	40.0	28.40

Female Branch Tee DTBF

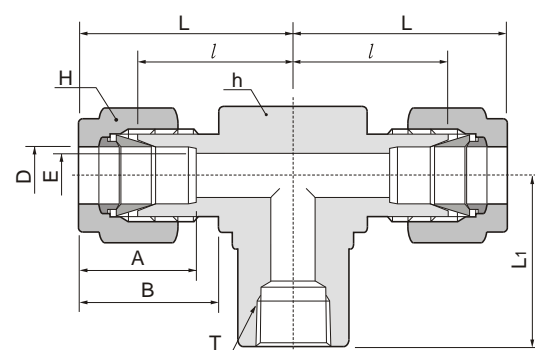

Connects fractional tube to male NPT thread

Part No.	Tube O.D. D		T (NPT)	E Min.	Width across flat				A	B	l	L	L1
	in	mm			h	mm	H	in					
DTBF 2-2N	1/8	3.17	1/8	2.28	1/2	12.70	7/16	11.11	12.70	15.24	18.03	24.38	19.05
DTBF 2-4N	1/8	3.17	1/4	2.28	11/16	17.46	7/16	11.11	12.70	15.24	20.82	27.43	22.35
DTBF 3-2N	3/16	4.76	1/8	3.04	1/2	12.70	1/2	12.70	13.71	16.00	18.79	25.40	19.05
DTBF 4-2N	1/4	6.35	1/8	4.82	1/2	12.70	9/16	14.28	15.24	17.78	19.55	26.92	19.05
DTBF 4-4N	1/4	6.35	1/4	4.82	11/16	17.46	9/16	14.28	15.24	17.78	22.35	29.71	22.35
DTBF 4-6N	1/4	6.35	3/8	4.82	13/16	20.64	9/16	14.28	15.24	17.78	24.38	31.75	22.35
DTBF 4-8N	1/4	6.35	1/2	4.82	1	25.40	9/16	14.28	15.24	17.78	27.17	34.54	28.44
DTBF 5-2N	5/16	7.94	1/8	6.35	9/16	14.28	5/8	15.87	16.25	18.54	21.33	28.70	19.05
DTBF 5-4N	5/16	7.94	1/4	6.35	11/16	17.46	5/8	15.87	16.25	18.54	23.11	30.48	22.35
DTBF 6-2N	3/8	9.52	1/8	7.11	5/8	15.87	11/16	17.46	16.76	19.30	23.11	30.48	19.05
DTBF 6-4N	3/8	9.52	1/4	7.11	11/16	17.46	11/16	17.46	16.76	19.30	23.87	31.24	22.35
DTBF 6-6N	3/8	9.52	3/8	6.35	13/16	20.64	11/16	17.46	16.76	19.30	25.90	33.27	22.35
DTBF 6-8N	3/8	9.52	1/2	7.11	1	25.40	11/16	17.46	16.76	19.30	28.70	36.06	28.44
DTBF 8-4N	1/2	12.70	1/4	10.41	13/16	20.64	7/8	22.22	22.86	21.84	25.90	36.06	22.35
DTBF 8-6N	1/2	12.70	3/8	10.41	13/16	20.64	7/8	22.22	22.86	21.84	25.90	36.06	22.35
DTBF 8-8N	1/2	12.70	1/2	10.41	1	25.40	7/8	22.22	22.86	21.84	29.71	39.87	28.44
DTBF10-6N	5/8	15.87	3/8	12.70	15/16	23.81	1	25.40	24.38	21.84	27.94	38.10	22.35
DTBF10-8N	5/8	15.87	1/2	12.70	1	25.40	1	25.40	24.38	21.84	28.70	38.86	28.44
DTBF12-8N	3/4	19.05	1/2	15.74	1-1/16	26.98	1-1/8	28.58	24.38	21.84	29.71	39.87	28.44
DTBF12-12N	3/4	19.05	3/4	15.74	1-1/4	31.75	1-1/8	28.58	24.38	21.84	34.54	44.70	31.75
DTBF14-12N	7/8	22.22	3/4	18.28	1-1/4	31.75	1-1/4	31.75	25.90	21.84	34.54	44.70	31.75
DTBF16-12N	1	25.40	3/4	22.35	1-27/64	36.00	1-1/2	38.10	31.24	26.41	36.83	49.02	31.75
DTBF16-16N	1	25.40	1	22.35	1-11/16	42.86	1-1/2	38.10	31.24	26.41	41.40	53.59	38.10

Connects metric tube to male NPT thread

Part No.	Tube O.D. D	T (NPT)	E Min.	Width across flat		A	B	l	L	L1
				h	H					
DTBF 6M-2N	6	1/8	4.8	12.70	14	15.3	17.7	19.6	27.0	19.00
DTBF 6M-4N	6	1/4	4.8	17.46	14	15.3	17.7	22.4	29.8	22.40
DTBF 6M-6N	6	3/8	4.8	20.64	14	15.3	17.7	24.4	31.7	22.40
DTBF 6M-8N	6	1/2	4.8	25.40	14	15.3	17.7	27.2	34.5	28.40
DTBF 8M-2N	8	1/8	6.4	15.87	16	16.2	18.6	23.1	29.9	19.00
DTBF 8M-4N	8	1/4	6.4	17.46	16	16.2	18.6	23.1	30.6	22.40
DTBF 8M-6N	8	3/8	6.4	20.64	16	16.2	18.6	25.2	32.4	22.40
DTBF 8M-8N	8	1/2	6.4	25.40	16	16.2	18.6	28.0	35.2	28.40
DTBF10M-2N	10	1/8	7.9	17.50	19	17.2	19.5	23.9	31.5	19.00
DTBF10M-4N	10	1/4	7.9	20.64	19	17.2	19.5	25.9	33.5	22.40
DTBF10M-6N	10	3/8	7.9	20.64	19	17.2	19.5	25.9	33.5	22.40
DTBF10M-8N	10	1/2	9.5	25.40	19	17.2	19.5	26.2	33.6	22.40
DTBF12M-4N	12	1/4	9.5	20.64	22	22.8	22.0	25.9	36.0	22.40
DTBF12M-6N	12	3/8	9.5	20.64	22	22.8	22.0	25.9	36.0	22.40
DTBF12M-8N	12	1/2	9.5	25.40	22	22.8	22.0	29.7	40.0	28.40
DTBF16M-8N	16	1/2	12.7	25.40	25	24.4	22.0	29.7	40.0	28.70

A, B & L are approximate figures in finger-tight.

Reducer DR

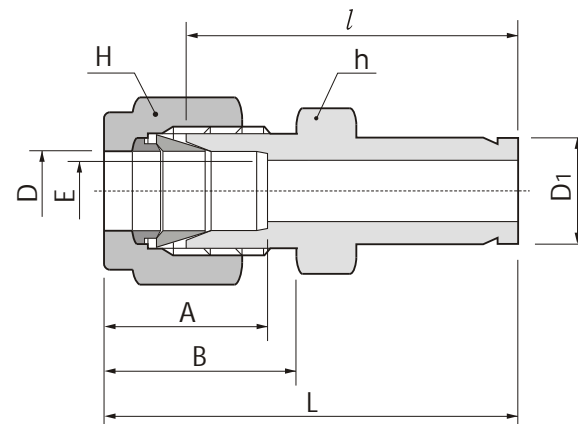
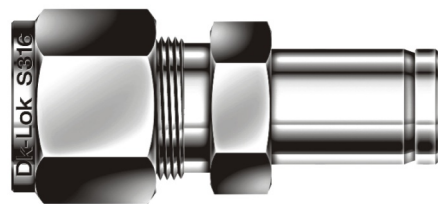

Connects fractional tube to fractional Dk-Lok port

Part No.	Tube O.D.				E Min.	Width across flat				A	B	l	L
	D		D1			h		H					
	in	mm	in	mm		in	mm	in	mm				
DR 1-2	1/16	1.59	1/8	3.17	1.27	5/16	7.93	5/16	7.93	8.63	10.92	25.40	29.21
DR 1-4	1/16	1.59	1/4	6.35	1.27	5/16	7.93	5/16	7.93	8.63	10.92	27.68	31.49
DR 2-1	1/8	3.17	1/16	1.59	1.76	7/16	11.11	7/16	11.11	12.70	15.24	22.35	28.95
DR 2-2	1/8	3.17	1/8	3.17	2.03	7/16	11.11	7/16	11.11	12.70	15.24	26.92	33.52
DR 2-3	1/8	3.17	3/16	4.76	2.28	7/16	11.11	7/16	11.11	12.70	15.24	27.68	34.29
DR 2-4	1/8	3.17	1/4	6.35	2.28	7/16	11.11	7/16	11.11	12.70	15.24	29.46	36.06
DR 2-6	1/8	3.17	3/8	9.52	2.28	7/16	11.11	7/16	11.11	12.70	15.24	30.98	37.59
DR 2-8	1/8	3.17	1/2	12.70	2.28	9/16	14.28	7/16	11.11	12.70	15.24	37.59	44.19
DR 3-2	3/16	4.76	1/8	3.17	2.03	7/16	11.11	1/2	12.70	13.71	16.00	28.19	34.79
DR 3-4	3/16	4.76	1/4	6.35	3.04	7/16	11.11	1/2	12.70	13.71	16.00	30.48	37.08
DR 4-2	1/4	6.35	1/8	3.17	2.03	1/2	12.70	9/16	14.28	15.24	17.78	29.46	36.83
DR 4-3	1/4	6.35	3/16	4.76	3.04	1/2	12.70	9/16	14.28	15.24	17.78	30.22	37.59
DR 4-4	1/4	6.35	1/4	6.35	4.82	1/2	12.70	9/16	14.28	15.24	17.78	31.75	39.11
DR 4-5	1/4	6.35	5/16	7.93	4.82	1/2	12.70	9/16	14.28	15.24	17.78	32.51	39.87
DR 4-6	1/4	6.35	3/8	9.52	4.82	1/2	12.70	9/16	14.28	15.24	17.78	33.27	40.64
DR 4-8	1/4	6.35	1/2	12.70	4.82	9/16	14.28	9/16	14.28	15.24	17.78	38.86	46.22
DR 4-10	1/4	6.35	5/8	15.87	4.82	11/16	17.46	9/16	14.28	15.24	17.78	40.64	48.00
DR 4-12	1/4	6.35	3/4	19.05	4.82	13/16	20.64	9/16	14.28	15.24	17.78	40.38	47.75
DR 5-6	5/16	7.93	3/8	9.52	6.35	9/16	14.28	5/8	15.87	16.25	18.54	34.54	41.91
DR 5-8	5/16	7.93	1/2	12.70	6.35	9/16	14.28	5/8	15.87	16.25	18.54	40.13	47.49
DR 6-4	3/8	9.52	1/4	6.35	4.82	5/8	15.87	11/16	17.46	16.76	19.30	34.03	41.40
DR 6-6	3/8	9.52	3/8	9.52	7.11	5/8	15.87	11/16	17.46	16.76	19.30	35.81	43.18
DR 6-8	3/8	9.52	1/2	12.70	7.11	5/8	15.87	11/16	17.46	16.76	19.30	41.14	48.51
DR 6-10	3/8	9.52	5/8	15.87	7.11	11/16	17.46	11/16	17.46	16.76	19.30	42.92	50.29
DR 6-12	3/8	9.52	3/4	19.05	7.11	13/16	20.64	11/16	17.46	16.76	19.30	42.92	50.29
DR 8-4	1/2	12.70	1/4	6.35	4.82	13/16	20.64	7/8	22.22	22.86	21.84	34.79	44.95
DR 8-6	1/2	12.70	3/8	9.52	7.11	13/16	20.64	7/8	22.22	22.86	21.84	36.57	46.73
DR 8-8	1/2	12.70	1/2	12.70	9.90	13/16	20.64	7/8	22.22	22.86	21.84	42.16	52.32
DR 8-10	1/2	12.70	5/8	15.87	10.41	13/16	20.64	7/8	22.22	22.86	21.84	43.68	53.84
DR 8-12	1/2	12.70	3/4	19.05	10.41	13/16	20.64	7/8	22.22	22.86	21.84	43.68	53.84
DR 8-16	1/2	12.70	1	25.40	10.41	1-1/16	26.98	7/8	22.22	22.86	21.84	50.03	60.19
DR10-12	5/8	15.87	3/4	19.05	12.70	15/16	23.81	1	25.40	24.38	21.84	44.45	54.61
DR10-14	5/8	15.87	7/8	22.22	12.70	15/16	23.81	1	25.40	24.38	21.84	45.97	56.13
DR10-16	5/8	15.87	1	25.40	12.70	1-1/16	26.98	1	25.40	24.38	21.84	50.80	60.96
DR12-8	3/4	19.05	1/2	12.70	9.90	1-1/16	26.98	1-1/8	28.57	24.38	21.84	44.45	54.61
DR12-16	3/4	19.05	1	25.40	15.74	1-1/16	26.98	1-1/8	28.57	24.38	21.84	52.32	62.48
DR16-20	1	25.40	1-1/4	31.75	22.35	1-3/8	34.93	1-1/2	38.10	31.24	26.41	68.32	80.51
DR16-24	1	25.40	1-1/2	38.10	22.35	1-5/8	41.28	1-1/2	38.10	31.24	26.41	76.96	89.15
DR16-32	1	25.40	2	50.80	22.35	2-1/8	53.98	1-1/2	38.10	31.24	26.41	100.33	112.52
DR20-24	1-1/4	31.75	1-1/2	38.10	27.68	1-7/8	47.63	2-1/4	57.15	41.14	38.86	82.04	104.14
DR20-32	1-1/4	31.75	2	50.80	27.68	1-7/8	47.63	3	76.20	41.14	38.86	103.12	125.22
DR24-32	1-1/2	38.10	2	50.80	34.03	2-1/4	57.15	3	76.20	50.03	45.21	104.14	131.31

Reducer DR

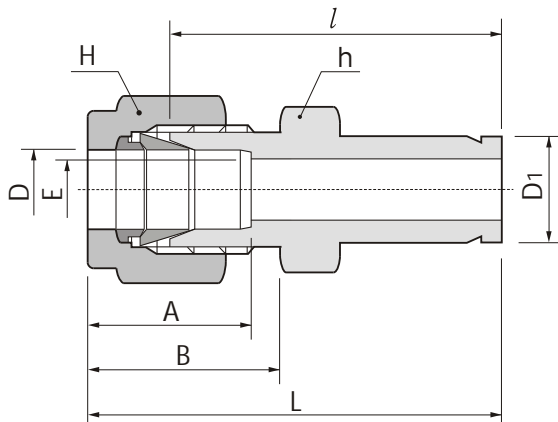
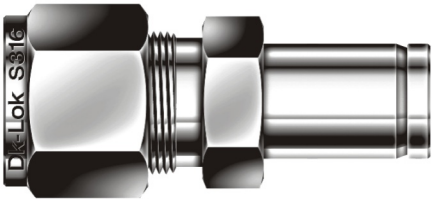

Connects metric tube to fractional Dk-Lok port

Part No.	Tube O.D.		E Min.	Width across flat		A	B	l	L	
	D	D1		h	H					
		in								mm
DR 2M-2	2	1/8	3.17	1.7	12	12	12.9	15.3	26.9	33.5
DR 3M-2	3	1/8	3.17	2.0	12	12	12.9	15.3	26.9	33.5
DR 3M-4	3	1/4	6.35	2.4	12	12	12.9	15.3	29.5	36.1
DR 4M-4	4	1/4	6.35	2.4	12	12	13.7	16.1	30.5	37.1
DR 6M-2	6	1/8	3.18	2.0	14	14	15.3	17.7	29.5	36.9
DR 6M-4	6	1/4	6.35	4.8	14	14	15.3	17.7	31.8	39.2
DR 6M-5	6	5/16	7.93	4.8	14	14	15.3	17.7	32.5	39.9
DR 6M-6	6	3/8	9.52	4.8	14	14	15.3	17.7	33.3	40.7
DR 6M-8	6	1/2	12.70	4.8	14	14	15.3	17.7	38.9	46.3
DR 8M-6	8	3/8	9.52	6.4	15	16	16.2	18.6	34.5	42.0
DR 8M-8	8	1/2	12.70	6.4	15	16	16.2	18.6	40.1	47.6
DR10M-6	10	3/8	9.52	7.1	18	19	17.2	19.5	36.6	44.2
DR10M-8	10	1/2	12.70	7.9	18	19	17.2	19.5	42.2	49.8
DR12M-8	12	1/2	12.70	9.5	22	22	22.8	22.0	42.2	52.3
DR12M-12	12	3/4	19.05	9.5	22	22	22.8	22.0	43.7	53.8
DR18M-12	18	3/4	19.05	15.1	27	30	24.4	22.0	46.0	56.1
DR18M-16	18	1	25.40	15.1	27	30	24.4	22.0	52.3	62.4
DR25M-16	25	1	25.40	20.2	35	38	31.3	26.5	57.2	69.5

Connects metric tube to metric Dk-Lok port

Part No.	Tube O.D.		E Min.	Width across flat		A	B	l	L
	D	D1		h	H				
		mm							
DR 2M-3M	2	3	1.7	12	12	12.9	15.3	26.9	35.3
DR 3M-4M	3	4	2.4	12	12	12.9	15.3	28.4	35.0
DR 3M-6M	3	6	2.4	12	12	12.9	15.3	29.5	36.1
DR 3M-10M	3	10	2.4	12	12	12.9	15.3	31.8	38.4
DR 4M-6M	4	6	2.4	12	12	13.7	16.1	30.5	37.1
DR 6M-3M	6	3	1.8	14	14	15.3	17.7	29.5	36.9
DR 6M-8M	6	8	4.8	14	14	15.3	17.7	32.5	39.9
DR 6M-10M	6	10	4.8	14	14	15.3	17.7	33.3	40.7
DR 6M-12M	6	12	4.8	14	14	15.3	17.7	38.9	46.3
DR 8M-6M	8	6	4.6	15	16	16.2	18.6	32.8	40.3
DR 8M-10M	8	10	6.4	15	16	16.2	18.6	34.5	42.0
DR 8M-12M	8	12	6.4	15	16	16.2	18.6	40.1	47.6
DR 10M-6M	10	6	4.6	18	19	17.2	19.5	34.8	42.4
DR 10M-12M	10	12	7.9	18	19	17.2	19.5	42.2	49.8
DR 10M-15M	10	15	7.9	18	19	17.2	19.5	43.7	51.3
DR 10M-18M	10	18	7.9	19	19	17.2	19.5	43.7	51.3
DR 12M-6M	12	6	4.6	22	22	22.8	22.0	34.8	44.9
DR 12M-10M	12	10	7.7	22	22	22.8	22.0	36.6	46.7
DR 12M-16M	12	16	9.5	22	22	22.8	22.0	43.7	53.8
DR 12M-18M	12	18	9.5	22	22	22.8	22.0	43.7	53.8
DR 12M-20M	12	20	9.5	22	22	22.8	22.0	46.0	56.1
DR 12M-22M	12	22	9.5	24	22	22.8	22.0	46.0	56.1
DR 12M-25M	12	25	9.5	27	22	22.8	22.0	52.3	62.4
DR 16M-12M	16	12	9.1	24	25	24.4	22.0	42.9	53.0
DR 18M-12M	18	12	9.1	27	30	24.4	22.0	44.5	54.6
DR 18M-16M	18	16	12.7	27	30	24.4	22.0	46.0	56.1
DR 18M-20M	18	20	15.1	27	30	24.4	22.0	47.5	57.6
DR 18M-22M	18	22	15.1	27	30	24.4	22.0	47.5	57.6
DR 18M-25M	18	25	15.1	27	30	24.4	22.0	52.3	62.4
DR 20M-16M	20	16	12.7	30	32	26.0	22.0	47.8	57.9
DR 20M-18M	20	18	13.9	30	32	26.0	22.0	47.8	57.9
DR 20M-22M	20	22	15.8	30	32	26.0	22.0	49.3	59.4
DR 20M-25M	20	25	15.8	30	32	26.0	22.0	54.1	64.2
DR 22M-18M	22	18	13.9	30	32	26.0	22.0	47.8	57.9
DR 22M-20M	22	20	15.1	30	32	26.0	22.0	49.3	59.4
DR 22M-25M	22	25	18.3	30	32	26.0	22.0	54.1	64.2
DR 25M-18M	25	18	13.9	35	38	31.3	26.5	50.8	63.1
DR 25M-20M	25	20	15.1	35	38	31.3	26.5	52.3	64.6

A, B & L are approximate figures in finger-tight.

Bulkhead Adapter **DAB**

The bulkhead adapter is useful for panel construction when you need to set a direction.

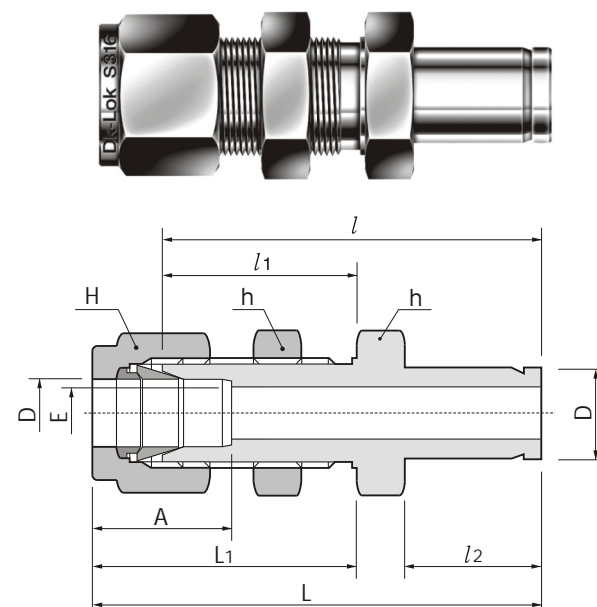
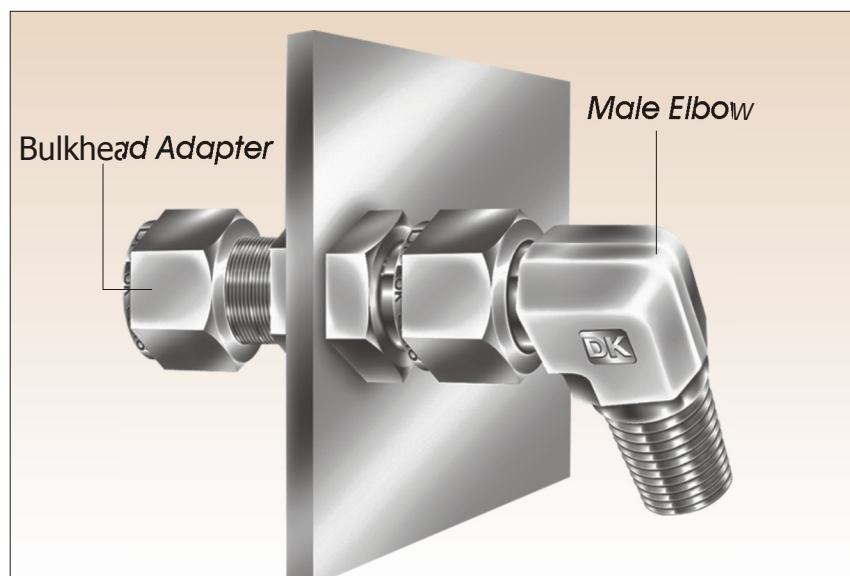

Connects fractional tube to fractional Dk-Lok port

Part No.	Tube O.D. D		E Min.	Width across flat				A	l	l ₁	l ₂	L	L ₁	Panel Hole Drill Size	Panel Max Thickness
	in	mm		h	H	in	mm								
DAB 2-2	1/8	3.17	2.03	1/2	12.70	7/16	11.11	12.70	42.92	24.63	13.45	49.53	31.24	8.33	12.70
DAB 4-4	1/4	6.35	4.82	5/8	15.87	9/16	14.28	15.24	48.51	26.16	15.74	55.88	33.52	11.50	10.16
DAB 6-6	3/8	9.52	7.11	3/4	19.05	11/16	17.46	16.76	53.84	29.46	17.50	61.21	36.83	14.68	11.17
DAB 8-8	1/2	12.70	10.41	15/16	23.81	7/8	22.22	22.86	62.73	31.75	23.11	72.89	41.91	19.44	12.70
DAB10-10	5/8	15.87	12.70	1-1/16	26.98	1	25.40	24.38	65.02	32.51	24.70	75.18	42.67	22.62	12.70
DAB16-16	1	25.40	20.32	1-5/8	41.28	1-1/2	38.10	31.24	88.13	45.21	31.70	100.33	57.40	33.73	19.05
DAB20-20	1-1/4	31.75	27.68	1-7/8	47.63	1-7/8	47.63	41.14	102.07	47.75	40.00	124.17	69.85	41.67	19.05
DAB24-24	1-1/2	38.10	34.03	2-1/4	57.15	2-1/4	57.15	50.03	118.33	49.27	51.50	145.51	76.45	49.61	19.05
DAB32-32	2	50.80	45.97	2-3/4	69.85	3	76.20	67.56	148.79	56.38	68.40	185.82	93.71	57.94	19.05

Male Adapter **DAM**

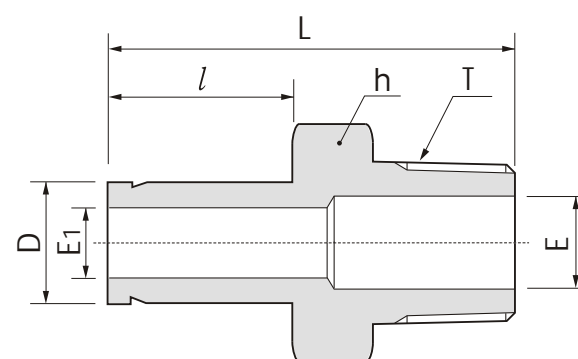
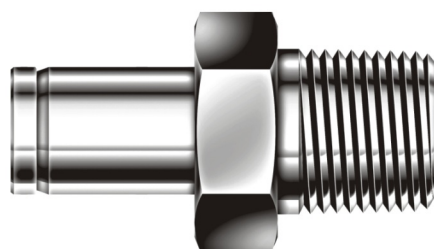

Connects metric Dk-Lok port to female ISO tapered thread

Part No.	Tube O.D. D	T R(PT)	E Min.	E1 Min.	Width across flat h	l	L
DAM 3M-2R	3	1/8	4.0	1.8	12	13.15	29.4
DAM 6M-2R	6	1/8	4.6	4.6	12	15.75	32.8
DAM 6M-4R	6	1/4	4.6	4.6	14	15.75	38.1
DAM 8M-4R	8	1/4	6.3	6.3	14	16.50	39.1
DAM 10M-4R	10	1/4	7.7	7.7	14	17.50	39.9
DAM 10M-6R	10	3/8	7.7	7.7	17	17.50	40.6
DAM 10M-8R	10	1/2	11.9	7.7	22	17.50	45.2
DAM 12M-4R	12	1/4	7.1	9.1	14	23.50	46.5
DAM 12M-6R	12	3/8	9.1	9.1	17	23.50	46.5
DAM 12M-8R	12	1/2	11.9	9.1	22	23.50	51.8
DAM 18M-8R	18	1/2	11.9	13.9	22	24.90	53.2
DAM 18M-12R	18	3/4	15.9	13.9	27	24.90	53.2
DAM 28M-16R	28	1	22.2	-	35	31.70	74.7
DAM 28M-20R	28	1-1/4	23.8	-	46	31.70	76.2
DAM 32M-20R	32	1-1/4	27.4	-	46	40.00	81.0
DAM 38M-24R	38	1-1/2	33.3	-	55	51.50	92.2

Male Adapter **DAM**

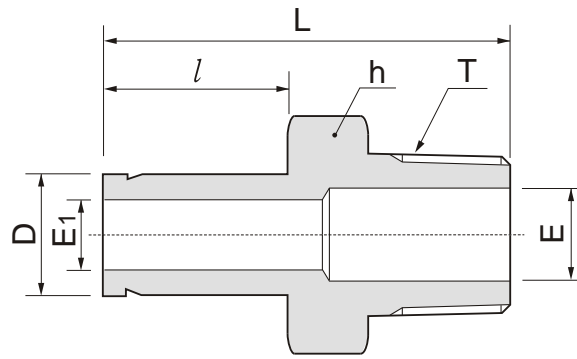
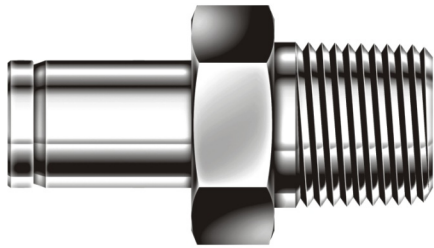

Connects fractional Dk-Lok port to female NPT thread

Part No.	Tube O.D. D		T (NPT)	E Min.	E1	Width across flat h		l	L
	in	mm				in	mm		
DAM 2-2N	1/8	3.17	1/8	4.57	1.77	7/16	11.11	13.45	29.50
DAM 2-4N	1/8	3.17	1/4	7.11	1.77	9/16	14.28	13.45	34.80
DAM 3-2N	3/16	4.76	1/8	4.57	3.04	7/16	11.11	14.20	30.22
DAM 3-4N	3/16	4.76	1/4	7.11	3.04	9/16	14.28	14.20	35.56
DAM 4-2N	1/4	6.35	1/8	4.57	4.57	7/16	11.11	15.75	31.80
DAM 4-4N	1/4	6.35	1/4	7.11	4.57	9/16	14.28	15.75	37.08
DAM 4-6N	1/4	6.35	3/8	10.41	4.57	11/16	17.46	15.75	37.84
DAM 4-8N	1/4	6.35	1/2	12.70	4.57	7/8	22.22	15.75	43.43
DAM 5-2N	5/16	7.93	1/8	4.57	6.35	7/16	11.11	16.80	32.76
DAM 5-4N	5/16	7.93	1/4	7.11	6.35	9/16	14.28	16.80	38.10
DAM 6-2N	3/8	9.52	1/8	4.57	7.11	7/16	11.11	17.50	33.50
DAM 6-4N	3/8	9.52	1/4	7.11	7.11	9/16	14.28	17.50	38.90
DAM 6-6N	3/8	9.52	3/8	10.41	7.11	11/16	17.46	17.50	39.60
DAM 6-8N	3/8	9.52	1/2	12.70	7.11	7/8	22.22	17.50	45.20
DAM 8-4N	1/2	12.70	1/4	7.11	9.90	9/16	14.28	23.20	44.50
DAM 8-6N	1/2	12.70	3/8	10.41	9.90	11/16	17.46	23.20	45.20
DAM 8-8N	1/2	12.70	1/2	12.70	9.90	7/8	22.22	23.20	50.50
DAM 10-6N	5/8	15.87	3/8	10.41	12.70	11/16	17.46	24.70	47.40
DAM 10-8N	5/8	15.87	1/2	12.70	12.70	7/8	22.22	24.70	52.30
DAM 10-12N	5/8	15.87	3/4	18.28	12.70	1-1/16	26.98	24.70	52.30
DAM 12-8N	3/4	19.05	1/2	12.70	14.98	7/8	22.22	24.70	52.30
DAM 12-12N	3/4	19.05	3/4	18.28	14.98	1-1/16	26.98	24.70	52.30
DAM 12-16N	3/4	19.05	1	22.35	14.98	1-3/8	34.92	24.70	57.91
DAM 14-12N	7/8	22.22	3/4	18.28	17.27	1-1/16	26.98	26.70	54.30
DAM 16-12N	1	25.40	3/4	18.28	20.06	1-1/16	26.98	31.70	58.70
DAM 16-16N	1	25.40	1	22.35	20.06	1-3/8	34.92	31.70	66.00
DAM 20-20N	1-1/4	31.75	1-1/4	27.68	-	1-3/4	44.45	40.00	80.26
DAM 24-24N	1-1/2	38.10	1-1/2	33.27	-	2-1/8	53.98	51.50	94.48
DAM 32-32N	2	50.80	2	44.45	-	2-3/4	69.85	68.40	119.38

Dk-Lok Adapter eliminates alignment problems

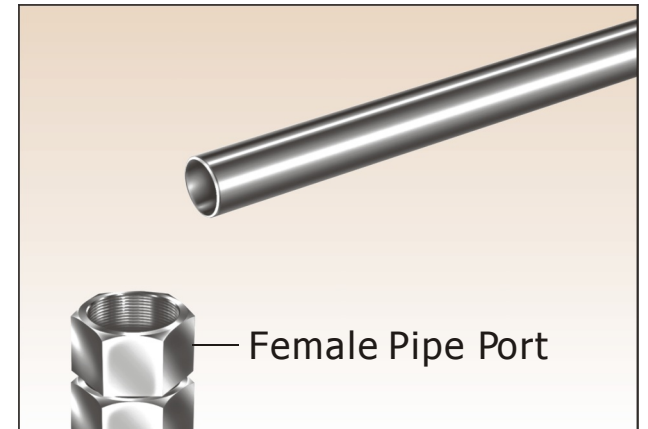

In the direction shown the female port is required to connect with tubing.

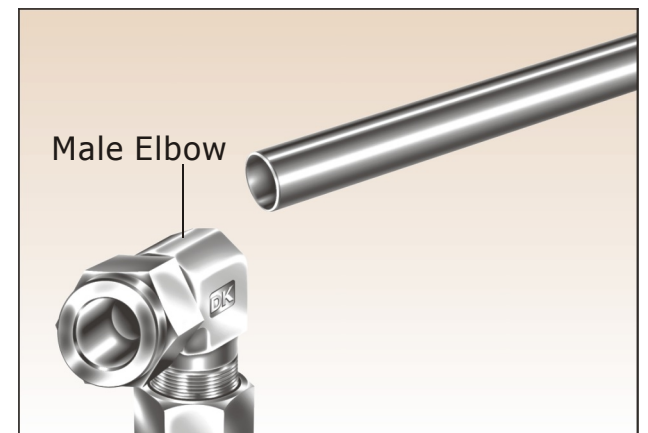

The male elbow is positioning in the wrong direction.

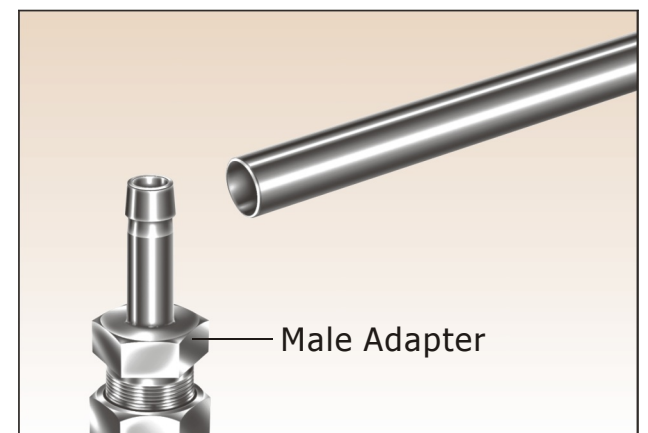

To eliminate the problem, use a male adapter into the female port.

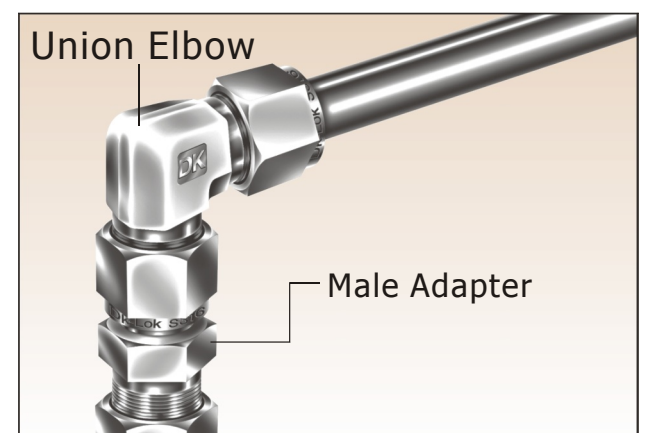

Connect a union elbow to the adapter by tightening the Dk-Lok port with a wrench while holding the elbow wrench pad in the desired direction

A, B & L are approximate figures in finger-tight.

All dimensions are in millimeters unless otherwise specified and only for reference subject to change.

Female Adapter DAF

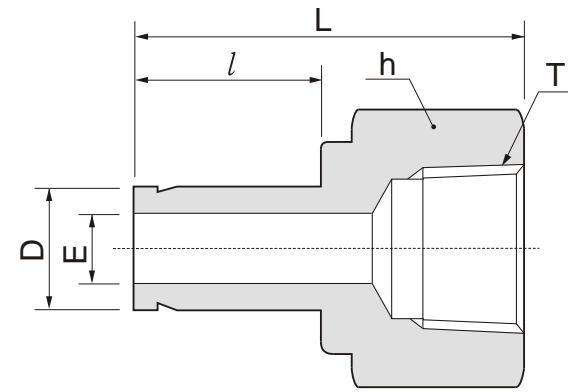
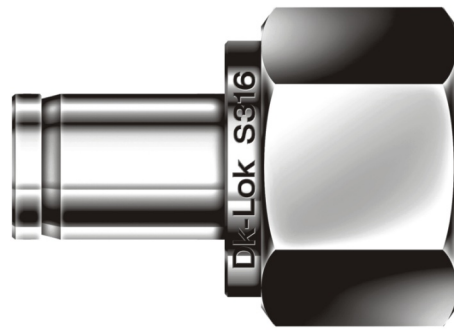

Connects fractional Dk-Lok port to male NPT thread

Part No.	Tube O.D. D		T (NPT)	E Min.	Width across flat h		l	L
	in	mm			in	mm		
DAF 2-2N	1/8	3.17	1/8	1.77	9/16	14.28	13.45	31.50
DAF 2-4N	1/8	3.17	1/4	1.77	3/4	19.05	13.45	35.30
DAF 3-2N	3/16	4.76	1/8	3.04	9/16	14.28	14.20	32.00
DAF 3-4N	3/16	4.76	1/4	3.04	3/4	19.05	14.20	35.81
DAF 4-2N	1/4	6.35	1/8	4.57	9/16	14.28	15.75	33.02
DAF 4-4N	1/4	6.35	1/4	4.57	3/4	19.05	15.75	37.10
DAF 4-6N	1/4	6.35	3/8	4.57	7/8	22.22	15.75	39.37
DAF 4-8N	1/4	6.35	1/2	4.57	1-1/16	26.98	15.75	45.50
DAF 5-2N	5/16	7.93	1/8	6.35	9/16	14.28	16.80	34.29
DAF 5-4N	5/16	7.93	1/4	6.35	3/4	19.05	16.80	37.59
DAF 6-2N	3/8	9.52	1/8	7.11	9/16	14.28	17.50	34.29
DAF 6-4N	3/8	9.52	1/4	7.11	3/4	19.05	17.50	38.10
DAF 6-6N	3/8	9.52	3/8	7.11	7/8	22.22	17.50	40.38
DAF 6-8N	3/8	9.52	1/2	7.11	1-1/16	26.98	17.50	46.73
DAF 8-4N	1/2	12.70	1/4	9.90	3/4	19.05	23.20	43.43
DAF 8-6N	1/2	12.70	3/8	9.90	7/8	22.22	23.20	45.46
DAF 8-8N	1/2	12.70	1/2	9.90	1-1/16	26.98	23.20	51.80
DAF 10-6N	5/8	15.87	3/8	12.70	7/8	22.22	24.70	48.26
DAF 10-8N	5/8	15.87	1/2	12.70	1-1/16	26.98	24.70	53.84
DAF 10-12N	5/8	15.87	3/4	12.70	1-5/16	33.33	24.70	55.37
DAF 12-8N	3/4	19.05	1/2	14.98	1-1/16	26.98	24.70	52.83
DAF 12-12N	3/4	19.05	3/4	14.98	1-5/16	33.33	24.70	54.86
DAF 12-16N	3/4	19.05	1	14.98	1-5/8	41.27	24.70	58.42
DAF 14-12N	7/8	22.22	3/4	17.27	1-5/16	33.33	26.70	57.15
DAF 16-12N	1	25.40	3/4	20.06	1-5/16	33.33	31.70	60.70
DAF 16-16N	1	25.40	1	20.06	1-5/8	41.27	31.70	64.26
DAF 20-20N	1-1/4	31.75	1-1/4	27.68	2-1/8	53.98	40.00	77.72
DAF 24-24N	1-1/2	38.10	1-1/2	33.27	2-3/8	60.33	51.50	88.90
DAF 32-32N	2	50.80	2	44.45	2-7/8	73.03	68.40	107.44

Connects metric Dk-Lok port to male ISO tapered thread

Part No.	Tube O.D. D	T R(PT)	E Min.	Width across flat h	l	L
DAF 3M-2R	3	1/8	1.8	14	13.15	31.15
DAF 6M-2R	6	1/8	4.6	14	15.75	32.50
DAF 6M-4R	6	1/4	4.6	19	15.75	37.10
DAF 8M-4R	8	1/4	6.3	19	16.50	37.60
DAF 10M-4R	10	1/4	7.7	19	17.50	38.10
DAF 10M-6R	10	3/8	7.7	22	17.50	40.10
DAF 10M-8R	10	1/2	7.7	27	17.50	46.50
DAF 12M-4R	12	1/4	9.1	19	23.50	43.70
DAF 12M-6R	12	3/8	9.1	22	23.50	46.00
DAF 12M-8R	12	1/2	9.1	27	23.50	52.30
DAF 18M-12R	18	3/4	13.9	32	24.90	54.80

Port Connector DCP

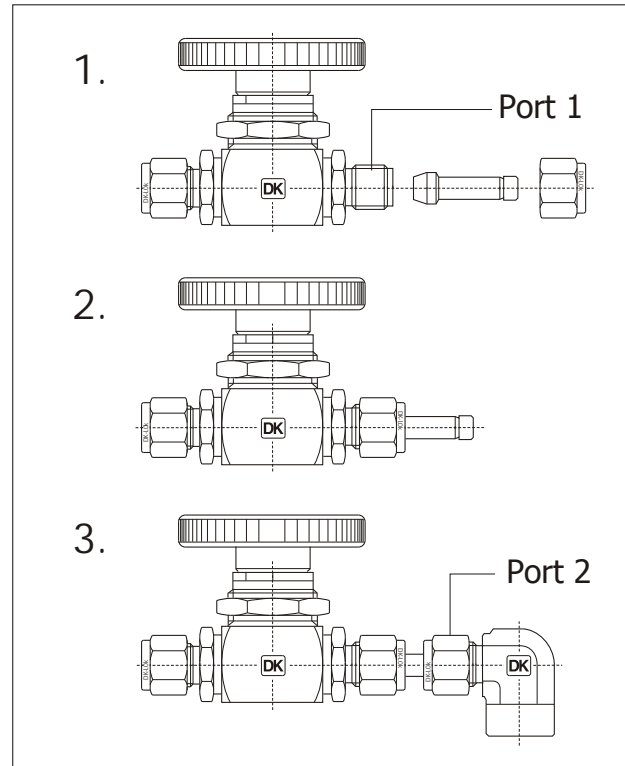
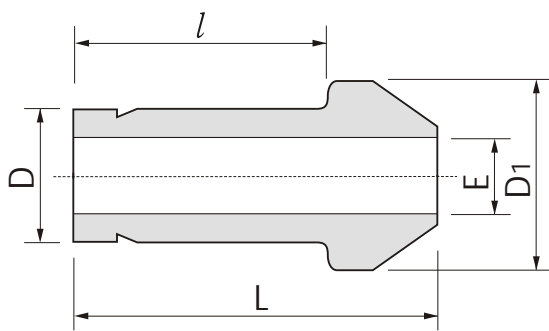
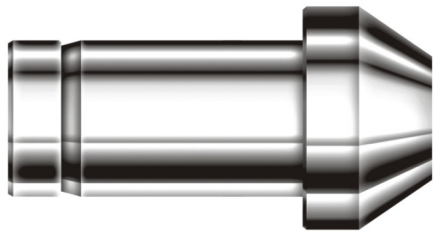

Dk-Lok port connector facilitates close connection to another port.

Installation Instructions

1. Remove the nut and ferrules from Dk-Lok port 1 and set nut only (no ferrules) over the port connector
2. Tighten the nut with wrench until sharp rise in torque is felt.
3. Insert the other end of port connector into port 2 and tighten nut 1-1/4 turns with wrench for 1/8", 3mm only 3/4 turn from finger tight.

Connects two fractional Dk-Lok ports

Part No.	Tube O.D.		E Min.	D1	l	L
	in	mm				
DCP-1	1/16	1.59	1.00	3.30	10.66	13.72
DCP-2	1/8	3.17	1.77	6.09	15.75	22.35
DCP-4	1/4	6.35	4.57	9.39	18.79	24.64
DCP-5	5/16	7.93	6.35	10.92	20.06	25.90
DCP-6	3/8	9.52	7.11	12.70	20.32	26.16
DCP-8	1/2	12.70	9.90	15.74	25.90	35.81
DCP-12	3/4	19.05	14.98	22.09	27.68	37.33
DCP-16	1	25.40	20.06	28.44	34.54	48.00

Connects two metric Dk-Lok ports

Part No.	Tube O.D.		E Min.	D1	l	L
	D					
DCP-3M	3	2.1	6.0	15.70	22.20	
DCP-4M	4	2.2	7.0	16.67	25.81	
DCP-6M	6	4.4	9.0	18.70	24.60	
DCP-8M	8	6.2	11.0	20.00	25.90	
DCP-10M	10	8.2	13.1	20.20	26.10	
DCP-12M	12	9.1	15.0	26.00	35.80	
DCP-15M	15	12.7	19.0	27.78	37.40	
DCP-16M	16	12.7	19.0	27.60	37.40	
DCP-18M	18	13.9	21.0	27.91	37.40	
DCP-20M	20	15.1	23.0	29.20	38.90	
DCP-22M	22	17.9	24.97	29.30	39.20	
DCP-25M	25	19.8	28.0	34.50	48.00	
DCP-28M	28	23.8	34.3	48.30	63.50	
DCP-32M	32	27.4	39.5	52.40	69.70	
DCP-38M	38	33.3	47.1	61.40	81.90	

Reducing Port Connector DCRP

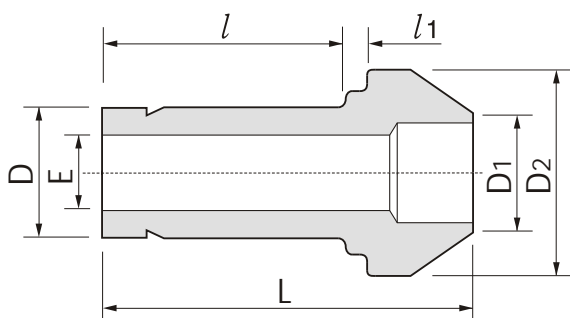
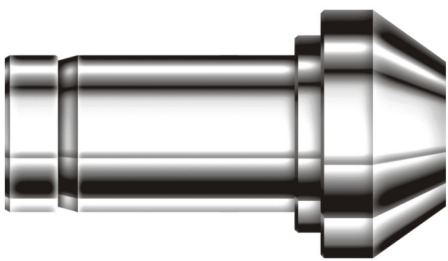

Connects two fractional Dk-Lok ports

Part No.	Tube O.D.				E Min.	D2	l	l1	L
	D1		D						
	in	mm	in	mm					
DCRP 2-1	1/8	3.17	1/16	1.59	1.00	6.10	8.64	2.03	17.27
DCRP 4-2	1/4	6.35	1/8	3.17	2.28	9.39	13.45	3.30	22.60
DCRP 6-2	3/8	9.52	1/8	3.17	2.28	12.70	13.45	3.81	23.11
DCRP 6-4	3/8	9.52	1/4	6.35	4.82	12.70	15.75	3.30	24.89
DCRP 8-4	1/2	12.70	1/4	6.35	4.82	15.74	15.75	3.81	29.21
DCRP 8-6	1/2	12.70	3/8	9.52	7.11	15.74	17.50	3.30	30.48
DCRP 12-8	3/4	19.05	1/2	12.70	9.90	22.09	23.20	3.81	37.85
DCRP 16-8	1	25.40	1/2	12.70	9.90	28.40	24.47	4.82	42.67
DCRP 16-12	1	25.40	3/4	19.05	14.98	28.40	25.90	4.06	43.43

Connects two metric Dk-Lok ports

Part No.	Tube O.D.		E Min.	D2	l	l1	L
	D1	D					
DCRP 6M-3M	6	3	2.2	9.0	13.50	3.2	22.60
DCRP 8M-6M	8	6	4.6	11.0	15.70	3.1	24.70
DCRP 10M-6M	10	6	4.6	13.1	15.70	3.4	25.00
DCRP 10M-8M	10	8	6.4	13.1	16.80	3.1	26.00
DCRP 12M-6M	12	6	4.6	15.0	15.70	3.6	29.10
DCRP 12M-8M	12	8	6.4	15.0	16.80	3.4	29.80
DCRP 12M-10M	12	10	7.7	15.0	17.50	3.1	30.40
DCRP 16M-6M	16	6	4.6	19.0	15.75	3.6	30.40
DCRP 16M-12M	16	12	9.1	19.0	23.10	3.4	36.20
DCRP 28M-25M	28	25	19.8	34.3	33.00	8.2	56.50
DCRP 32M-25M	32	25	19.8	39.5	33.00	9.9	60.30
DCRP 38M-25M	38	25	19.8	47.1	33.00	12.3	65.80

A, B & L are approximate figures in finger-tight.

All dimensions are in millimeters unless otherwise specified and only for reference subject to change.

Dk-Lok[®] Tube Fittings

AN Union DUA

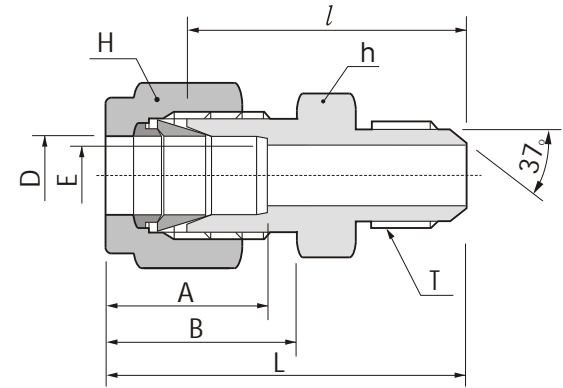
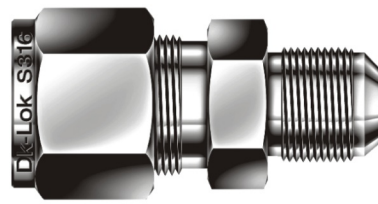

Connects fractional tube to AN flared tube

Part No.	Tube O.D. D		AN Tube Flare Size		Straight Thread T(U)	E Min.	Width across flat				A	B	l	L
	in	mm	in	mm			h		H					
							in	mm	in	mm				
DUA 1-2	1/16	1.59	1/8	3.17	5/16-24	1.27	7/16	11.11	5/16	7.93	8.63	10.92	23.36	27.17
DUA 2-2	1/8	3.17	1/8	3.17	5/16-24	1.52	7/16	11.11	7/16	11.11	12.70	15.24	24.89	31.49
DUA 2-4	1/8	3.17	1/4	6.35	7/16-20	2.28	1/2	12.70	7/16	11.11	12.70	15.24	28.44	35.05
DUA 4-4	1/4	6.35	1/4	6.35	7/16-20	4.31	1/2	12.70	9/16	14.28	15.24	17.78	30.22	37.59
DUA 5-5	5/16	7.93	5/16	7.93	1/2-20	5.84	9/16	14.28	5/8	15.87	16.25	18.54	30.98	38.35
DUA 6-4	3/8	9.52	1/4	6.35	7/16-20	4.31	5/8	15.87	11/16	17.46	16.76	19.30	32.25	39.62
DUA 6-6	3/8	9.52	3/8	9.52	9/16-18	7.11	5/8	15.87	11/16	17.46	16.76	19.30	32.25	39.62
DUA 8-8	1/2	12.70	1/2	12.70	3/4-16	9.90	13/16	20.64	7/8	22.22	22.86	21.84	35.81	45.97
DUA12-12	3/4	19.05	3/4	19.05	1-1/16-12	15.49	1-1/8	28.58	1-1/8	28.58	24.38	21.84	43.18	53.34
DUA16-16	1	25.40	1	25.40	1-5/16-12	21.33	1-3/8	34.92	1-1/2	38.10	31.24	26.41	49.27	61.46
DUA 20-20	1-1/4	31.75	1-1/4	31.75	1-5/8-12	27.68	1-3/4	44.45	1-7/8	47.63	41.14	38.86	44.46	77.56
DUA 24-24	1-1/2	38.10	1-1/2	38.10	1-7/8-12	34.03	2-1/8	53.97	2-1/4	57.15	50.03	45.21	63.07	90.25
DUA 32-32	2	50.80	2	50.80	2-1/2-12	45.97	2-3/4	69.85	3	76.20	67.56	62.73	83.24	120.57

AN Bulkhead Union DUBA

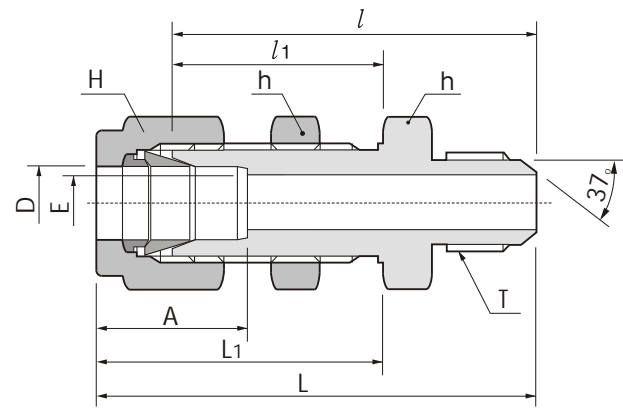
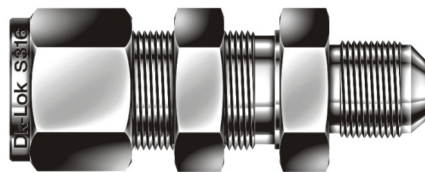

Connects fractional tube to AN flared tube

Part No.	Tube O.D. D		AN Tube Flare Size		Straight Thread T(U)	E Min.	Width across flat				A	l	l ₁	L	L ₁	Panel Hole Drill Size	Panel Max Thickness
	in	mm	in	mm			h		H								
							in	mm	in	mm							
DUBA 2-2	1/8	3.17	1/8	3.17	5/16-24	1.77	1/2	12.70	7/16	11.11	13.71	40.85	24.63	47.45	31.23	8.33	12.70
DUBA 4-4	1/4	6.35	1/4	6.35	7/16-20	4.31	5/8	15.87	9/16	14.28	15.24	46.48	26.16	53.84	33.52	11.50	10.16
DUBA 6-6	3/8	9.52	3/8	9.52	9/16-18	7.11	3/4	19.05	11/16	17.46	16.76	49.78	29.46	57.15	36.83	14.68	11.17
DUBA 8-8	1/2	12.70	1/2	12.70	3/4-16	9.90	5/16	23.81	7/8	22.22	22.86	55.62	31.75	65.78	41.91	19.44	12.70
DUBA12-12	3/4	19.05	3/4	19.05	1-1/16-12	15.49	1-3/16	30.16	1-1/8	28.58	24.38	68.83	37.33	78.99	47.49	25.79	16.76
DUBA16-16	1	25.40	1	25.40	1-5/16-12	21.33	1-5/8	41.27	1-1/2	38.10	31.24	80.26	45.21	92.45	57.40	33.73	19.05
DUBA20-20	1-1/4	31.75	1-1/4	31.75	1-5/8-12	27.68	1-7/8	47.63	1-7/8	47.63	41.14	86.37	47.75	108.47	69.85	41.67	19.05
DUBA24-24	1-1/2	38.10	1-1/2	38.10	1-7/8-12	34.03	2-1/4	57.15	2-1/4	57.15	50.03	94.33	49.27	121.51	76.45	49.61	19.05
DUBA32-32	2	50.80	2	50.80	2-1/2-12	45.97	2-3/4	69.85	3	76.20	67.56	114.29	56.38	151.62	93.71	16.27	19.05

AN Adapter DAA

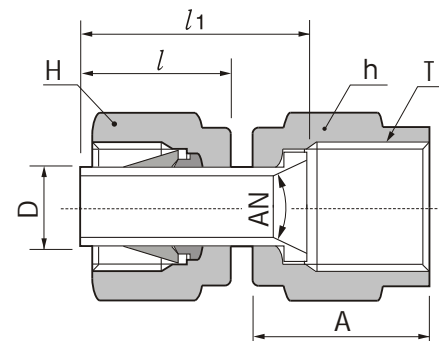

Connects fractional Dk-Lok port to male AN

Part No.	Tube O.D. D		AN Tube Flare Size		Straight Thread T(U)	Width across flat				A	l	l ₁
	in	mm	in	mm		h		H				
						in	mm	in	mm			
DAA 2-2	1/8	3.17	1/8	3.17	5/16-24	3/8	9.52	7/16	11.11	13.71	13.46	18.54
DAA 2-4	1/8	3.17	1/4	6.35	7/16-20	9/16	14.28	7/16	11.11	15.74	13.46	19.05
DAA 4-4	1/4	6.35	1/4	6.35	7/16-20	9/16	14.28	9/16	14.28	15.74	15.74	21.33
DAA 6-6	3/8	9.52	3/8	9.52	9/16-18	11/16	17.46	11/16	17.46	18.28	17.52	24.89
DAA 8-8	1/2	12.70	1/2	12.70	3/4-16	7/8	22.22	7/8	22.22	21.59	23.11	31.75

SAE Fittings

Dk-Lok SAE Straight O-Ring Seal Fittings are of positionable feature and provide connection tube to straight thread boss. Further this has an advantage of eliminating welding and brazing process when used as bulkhead fitting on thin wall tanks or vessels.

These fittings are designed and manufactured to SAE standards as below:

- Male or External Fitting End Dimensions to SAE J514
- Straight thread to SAE J475 (equivalent to ANSI B1.1 or ISO R725)
- Female or Internal Straight Thread Boss to SAE J1926. See diagram below.

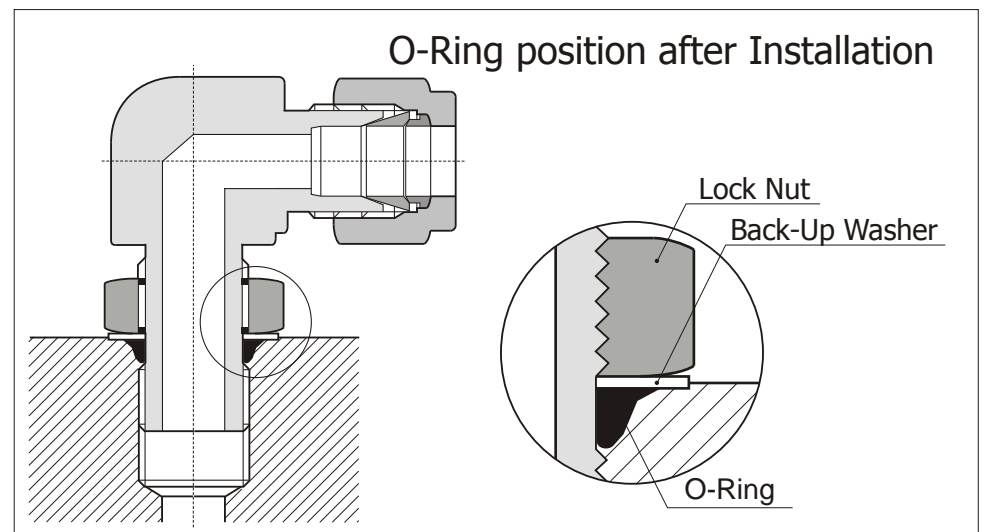
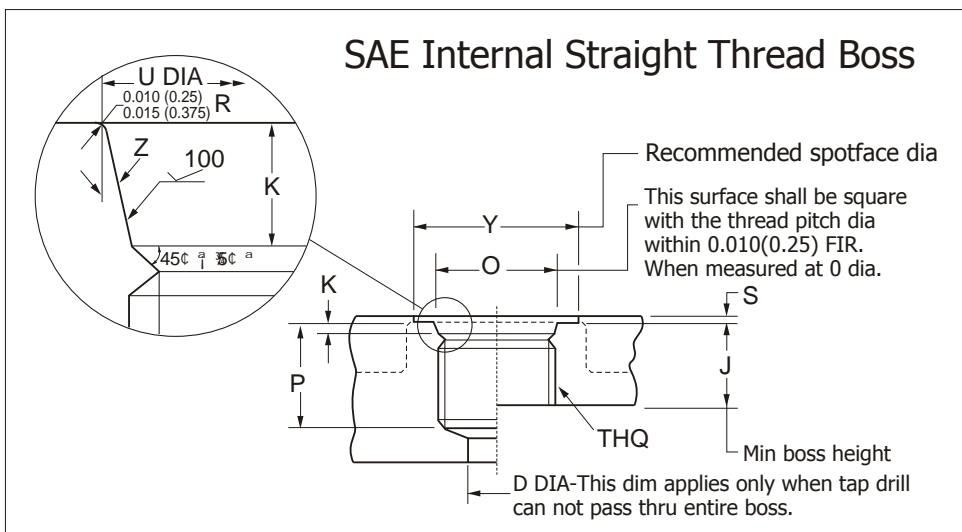

Details of SAE Internal Straight Thread Boss

Unit:mm

Nominal Tube O.D.	Thread Size	D Min.	J Min.	K (± 0.2)	O Min.	Pd Min.	Ua (+0.13)	Yc	Sbc Max	Z (± 1.0)
1/8	5/16-24	1.6	10.0	1.9	11	12.0	9.1	17	1.6	12.0
3/16	3/8-24	3.2	10.0	1.9	13	12.0	10.7	19	1.6	12.0
1/4	7/16-20	4.4	11.5	2.4	15	14.0	12.4	21	1.6	12.0
5/16	1/2-20	6.0	11.5	2.4	16	14.0	14.0	23	1.6	12.0
3/8	9/16-18	7.5	12.7	2.5	18	15.5	15.6	25	1.6	12.0
1/2	3/4-16	10.0	14.3	2.5	22	17.5	20.6	30	2.4	15.0
5/8	7/8-14	12.5	16.7	2.5	26	20.0	23.9	34	2.4	15.0
3/4	1-1/16-12	16.0	19.0	3.3	32	23.0	29.2	41	2.4	15.0
7/8	1-3/16-12	18.0	19.0	3.3	35	23.0	32.3	45	2.4	15.0
1	1-5/16-12	21.0	19.0	3.3	38	23.0	35.5	49	3.2	15.0
1-1/4	1-5/8-12	27.0	19.0	3.3	48	23.0	43.5	58	3.2	15.0
1-1/2	1-7/8-12	33.0	19.0	3.3	54	23.0	49.8	65	3.2	15.0
2	2-1/2-12	70.0	19.0	3.3	70	23.0	65.7	88	3.2	15.0

- a. Diameter U shall be concentric with the thread pitch diameter within 0.13 full indicator reading (FIR) and shall be free from longitudinal and spiral tool marks. Annular tool marks up to 2.5 Micro meters max. shall be permissible.
- b. This is the Maximum recommended spotface depth to permit sufficient wrench grip for the proper tightening of the fitting or locknut.
- c. If the face of the boss is on a machined surface, dimensions Y and S need not apply as long as R 0.25/ 0.375 is maintained to avoid damage to the O - Ring during installation.
- d. Tap drill depths given require the use of bottoming taps to produce the specified full thread lengths. Where standard taps are used, the tap drill depths must be increased accordingly.

O-Ring and straight thread size for SAE Fittings Bosses

Nominal Tube O.D.	Port Size	Thread Size	O -Ring		
			Size No.	I.D. inch	Cross Section inch
1/8	2	5/16-24	902	0.239	0.064
3/16	3	3/8-24	903	0.301	0.064
1/4	4	7/16-20	904	0.351	0.072
5/16	5	1/2-20	905	0.414	0.072
3/8	6	9/16-18	906	0.468	0.078
1/2	8	3/4-16	908	0.644	0.087
5/8	10	7/8-14	910	0.755	0.097
3/4	12	1-1/16-12	912	0.924	0.116
7/8	14	1-3/16-12	914	1.048	0.116
1	16	1-5/16-12	916	1.171	0.116
1-1/4	20	1-5/8-12	920	1.475	0.118
1-1/2	24	1-7/8-12	924	1.720	0.118
2	32	2-1/2-12	932	2.337	0.118

Installation Instruction

- Step 1. Ensure the locknut is fully raised.
- Step 2. Lubricate the O-Ring with a light oil or petroleum and turn the fitting into the straight thread boss until the metal washer is in contact with the boss
- Step 3. Position the fitting by backing it out (not more than 1 turn counter-clockwise) until the Dk-Lok fitting is oriented in the desired direction.
- Step 4. With a back up wrench, hold the wrench pad and tighten the locknut until the washer is set against the face of the boss.

SAE Male Connector DMCS

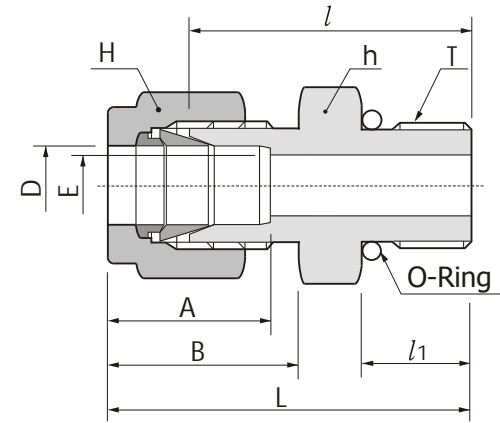
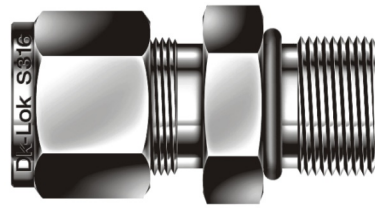

Connects fractional tube to SAE straight thread boss

Part No.	Tube O.D. D		Straight Thread T(u)	E Min.	Width across flat				A	B	l	l ₁	L	O-Ring Unifom Size Number
	in	mm			h	H	in	mm						
DMCS 2-2U	1/8	3.17	5/16-24	2.28	7/16	11.11	7/16	11.11	12.70	15.24	23.26	7.62	29.97	-902
DMCS 4-4U	1/4	6.35	7/16-20	4.82	9/16	14.28	9/16	14.28	15.24	17.78	26.67	9.14	34.03	-904
DMCS 4-6U	1/4	6.35	9/16-18	4.82	11/16	17.46	9/16	14.28	15.24	17.78	28.19	9.90	35.56	-906
DMCS 4-8U	1/4	6.35	3/4-16	4.82	7/8	22.22	9/16	14.28	15.24	17.78	30.22	11.17	37.59	-908
DMCS 4-10U	1/4	6.35	7/8-14	4.82	1	25.40	9/16	14.28	15.24	17.78	33.27	12.70	40.64	-910
DMCS 5-5U	5/16	7.93	1/2-20	5.84	5/8	15.87	5/8	15.87	16.25	18.54	27.43	9.14	34.79	-905
DMCS 6-4U	3/8	9.52	7/16-20	5.08	5/8	15.87	11/16	17.46	16.76	19.30	28.19	9.14	35.56	-904
DMCS 6-6U	3/8	9.52	9/16-18	7.11	11/16	17.46	11/16	17.46	16.76	19.30	29.71	9.90	37.08	-906
DMCS 6-8U	3/8	9.52	3/4-16	7.11	7/8	22.22	11/16	17.46	16.76	19.30	31.75	11.17	39.11	-908
DMCS 6-10U	3/8	9.52	7/8-14	7.11	1	25.40	11/16	17.46	16.76	19.30	34.79	12.70	42.16	-910
DMCS 8-6U	1/2	12.70	9/16-18	7.11	13/16	20.64	7/8	22.22	22.86	21.84	28.95	9.90	39.11	-906
DMCS 8-8U	1/2	12.70	3/4-16	10.41	7/8	22.22	7/8	22.22	22.86	21.84	31.75	11.17	41.91	-908
DMCS 8-10U	1/2	12.70	7/8-14	10.41	1	25.40	7/8	22.22	22.86	21.84	34.79	12.70	44.95	-910
DMCS 8-12U	1/2	12.70	1-1/16-12	10.41	1-1/4	31.75	7/8	22.22	22.86	21.84	38.86	14.98	49.02	-912
DMCS 10-8U	5/8	15.87	3/4-16	10.66	15/16	23.81	1	25.40	24.38	21.84	31.75	11.17	41.91	-908
DMCS 10-10U	5/8	15.87	7/8-14	12.70	1	25.40	1	25.40	24.38	21.84	35.05	12.70	45.21	-910
DMCS 12-8U	3/4	19.05	3/4-16	10.66	1-1/16	26.98	1-1/8	28.57	24.38	21.84	35.81	11.17	45.97	-908
DMCS 12-12U	3/4	19.05	1-1/16-12	15.74	1-1/4	31.75	1-1/8	28.57	24.38	21.84	38.86	14.98	49.02	-912
DMCS 14-14U	7/8	22.22	1-3/16-12	18.28	1-3/8	34.92	1-1/4	31.75	25.90	21.84	38.86	14.98	49.02	-914
DMCS 16-12U	1	25.40	1-1/16-12	16.76	1-3/8	34.92	1-1/2	38.10	31.24	26.41	41.14	14.98	53.34	-912
DMCS 16-16U	1	25.40	1-5/16-12	22.35	1-1/2	38.10	1-1/2	38.10	31.24	26.41	42.16	14.98	54.35	-916
DMCS 20-20U	1-1/4	31.75	1-5/8-12	27.68	1-7/8	47.63	1-7/8	47.63	41.14	38.86	46.22	14.98	68.32	-920
DMCS 24-24U	1-1/2	38.10	1-7/8-12	34.03	2-1/8	53.98	2-1/4	57.15	50.03	45.21	50.54	14.98	77.72	-924
DMCS 32-32U	2	50.80	2-1/2-12	45.97	2-3/4	69.85	3	76.20	67.56	62.73	64.26	14.98	101.60	-932

Positionable SAE Male Elbow DLS

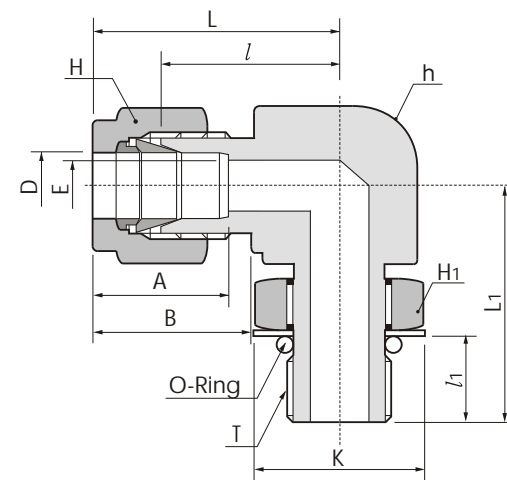

Connects fractional tube to SAE straight thread boss

Part No.	Tube O.D. D		Straight Thread T(u)	E Min.	Width across flat					A	B	l	l ₁	L	L ₁	K	O-Ring Unifom Size Number	
	in	mm			h	H	H ₁	in	mm									in
DLS 4-4U	1/4	6.35	7/16-20	4.82	1/2	12.70	9/16	14.28	9/16	14.28	15.24	17.78	21.08	9.90	28.44	28.44	16.51	-904
DLS 5-5U	5/16	7.93	1/2-20	5.84	9/16	14.28	5/8	15.87	5/8	15.87	16.25	18.54	22.86	9.90	30.22	29.46	18.28	-905
DLS 6-6U	3/8	9.52	9/16-18	7.11	5/8	15.87	11/16	17.46	11/16	17.46	16.76	19.30	24.63	11.17	32.00	32.25	20.06	-906
DLS 6-8U	3/8	9.52	3/4-16	7.11	13/16	20.64	11/16	17.46	7/8	22.22	16.76	19.30	27.43	12.70	34.79	37.84	25.65	-908
DLS 8-8U	1/2	12.70	3/4-16	10.41	13/16	20.64	7/8	22.22	7/8	22.22	22.86	21.84	27.43	12.70	37.59	37.84	25.65	-908
DLS10-10U	5/8	15.87	7/8-14	12.70	1	25.40	1	25.40	1	25.40	24.38	21.84	29.46	14.22	39.62	43.43	29.46	-910
DLS12-12U	3/4	19.05	1-1/16-12	15.74	1-1/16	26.98	1-1/8	28.57	1-1/4	31.75	24.38	21.84	31.24	16.76	41.40	48.76	36.57	-912
DLS14-14U	7/8	22.22	1-3/16-12	18.28	1-1/4	31.75	1-1/4	31.75	1-3/8	34.92	25.90	21.84	33.02	16.76	43.18	50.54	40.38	-914
DLS16-16U	1	25.40	1-5/16-12	22.35	1-3/8	34.92	1-1/2	38.10	1-1/2	38.10	31.24	26.41	38.35	16.76	50.54	53.59	43.94	-916
DLS 20-20U	1-1/4	31.75	1-5/8-12	27.68	1-11/16	42.76	1-7/8	47.63	1-7/8	47.63	41.14	38.86	45.72	16.76	67.81	58.16	54.86	-920
DLS 24-24U	1-1/2	38.10	1-7/8-12	34.03	2	50.80	2-1/4	57.15	2-1/8	53.98	50.03	45.21	50.80	16.76	77.97	60.45	62.23	-924
DLS 32-32U	2	50.80	2-1/2-12	45.97	2-3/4	69.85	3	76.20	2-3/4	69.85	67.56	62.73	69.85	16.76	107.18	71.62	80.26	-932

Dk-Lok[®]
Tube Fittings

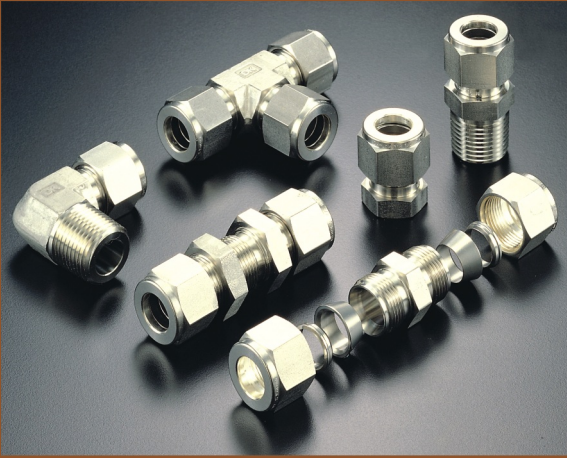

Dk-Lok[®] S316



Dk-Lok[®]
Brass & Steel



Dk-Lok[®] Teflon



Dk-Lok[®]
Over 1" and
Pre-Swaging Unit
DHS-1A

GREEN[®]
Pipe Fittings



Green
Thread and Weld
Fittings
S316, Brass Steel

D-PRO[™]
Valves



63/66 Series
Relief Valves



33 Series
Check Valves



46 Series
Gauge Root Valves



15 Series
Needle Valves



86 Series
Ball Valves



16 Series Union
Bonnet Valves



56 Series Manifolds

Positionable 45° SAE Male Elbow **DLBS**

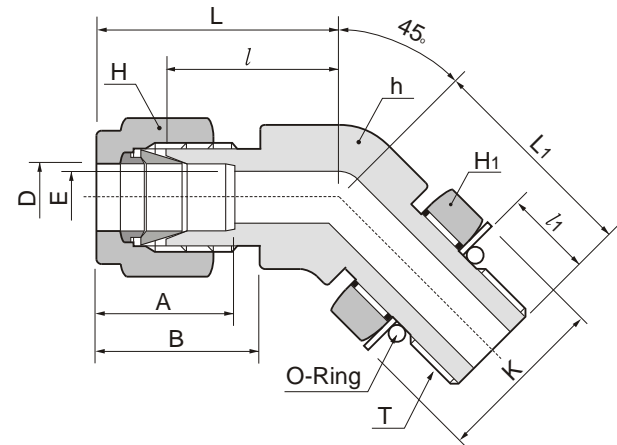
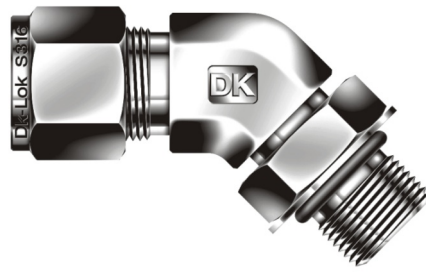

Connects fractional tube to SAE straight thread boss

Part No.	Tube O.D. D		Straight Thread T(u)	E Min.	Width across flat			A	B	l	l ₁	L	L ₁	K	O-Ring Uniform Size Number			
	in	mm			h	H	H ₁											
DLBS 4-4U	1/4	6.35	7/16-20	4.82	1/2	12.70	9/16	14.28	9/16	14.28	15.24	17.78	18.28	9.90	25.65	25.65	16.51	-904
DLBS 6-6U	3/8	9.52	9/16-18	7.11	5/8	15.87	11/16	17.46	11/16	17.46	16.76	19.30	20.57	11.17	27.94	28.19	20.06	-906
DLBS 8-8U	1/2	12.70	3/4-16	10.41	13/16	20.64	7/8	22.22	7/8	22.22	22.86	21.84	21.84	12.70	32.00	32.25	25.65	-908
DLBS12-12U	3/4	19.05	1-1/16-12	15.74	1-1/8	28.58	1-1/8	28.58	1-1/4	31.75	24.38	21.84	29.71	16.76	39.87	47.24	36.57	-912
DLBS16-16U	1	25.40	1-5/16-12	22.35	1-3/8	34.92	1-1/2	38.10	1-1/2	38.10	31.24	26.41	35.30	16.76	47.49	50.54	43.94	-916

Positionable SAE Male Run Tee **DTRS**

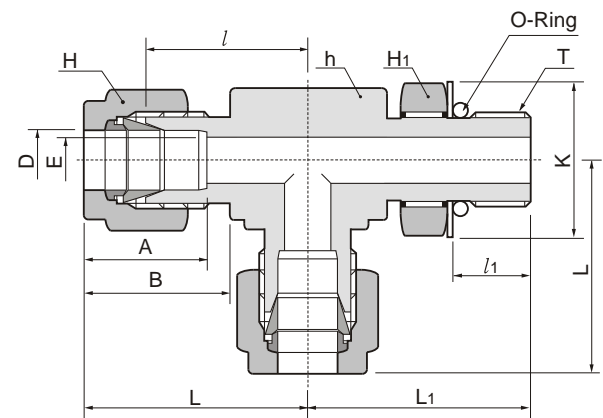
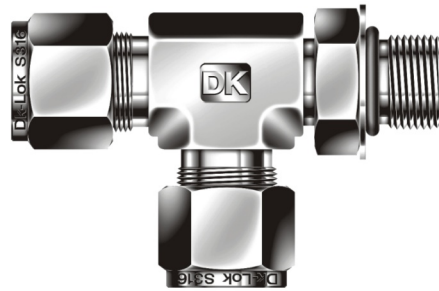

Connects fractional tube to SAE straight thread boss

Part No.	Tube O.D. D		Straight Thread T(u)	E Min.	Width h across flat			A	B	l	l ₁	L	L ₁	K	O-Ring Uniform Size Number			
	in	mm			h	H	H ₁											
DTRS 4-4U	1/4	6.35	7/16-20	4.82	1/2	12.70	9/16	14.28	9/16	14.28	15.24	17.78	21.08	9.90	28.44	28.44	16.51	-904
DTRS 6-6U	3/8	9.52	9/16-18	7.11	5/8	15.87	11/16	17.46	11/16	17.46	16.76	19.30	24.63	11.17	32.00	32.25	20.06	-906
DTRS 8-8U	1/2	12.70	3/4-16	10.41	13/16	20.64	7/8	22.22	7/8	22.22	22.86	21.84	27.43	12.70	37.59	37.84	25.65	-908
DTRS12-12U	3/4	19.05	1-1/16-12	15.74	1-1/8	26.98	1-1/8	28.58	1-1/4	31.75	24.38	21.84	31.24	16.76	41.40	48.76	36.57	-912
DTRS16-16U	1	25.40	1-5/16-12	22.35	1-3/8	34.92	1-1/2	38.10	1-1/2	38.10	31.24	26.41	38.35	16.76	50.54	50.54	43.94	-916
DTRS 20-20U	1-1/4	31.75	1-5/8-12	27.68	1-11/16	42.86	1-7/8	47.63	1-7/8	47.63	41.14	38.86	45.72	16.76	67.81	58.16	54.86	-920
DTRS 24-24U	1-1/2	38.10	1-7/8-12	34.03	2	50.80	2-1/4	57.15	2-1/8	53.98	50.03	45.21	50.80	16.76	77.97	60.45	62.23	-924
DTRS 32-32U	2	50.80	2-1/2-12	45.97	2-3/4	69.85	3	76.20	2-3/4	69.85	67.56	62.73	69.85	16.76	107.18	71.62	80.26	-932

Positionable SAE Male Branch Tee **DTBS**

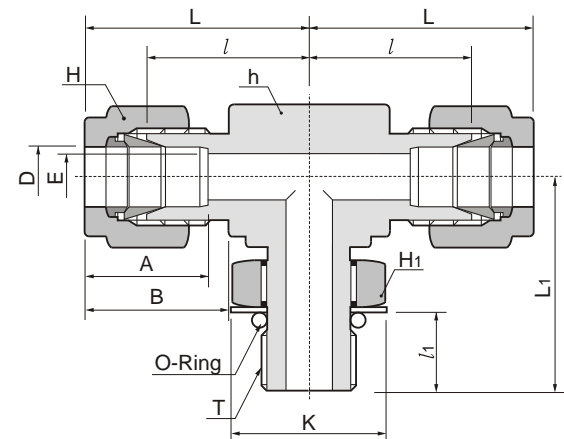
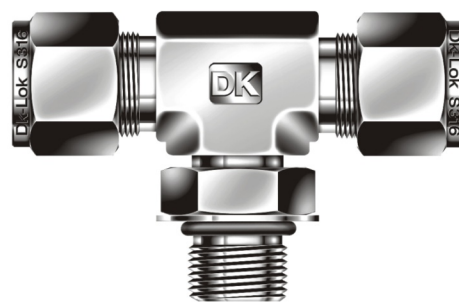

Connects fractional tube to SAE straight thread boss

Part No.	Tube O.D. D		Straight Thread T(u)	E Min.	Width across flat			A	B	l	l ₁	L	L ₁	K	O-Ring Uniform Size Number			
	in	mm			h	H	H ₁											
DTBS 4-4U	1/4	6.35	7/16-20	4.82	1/2	12.70	9/16	14.28	9/16	14.28	15.24	17.78	21.08	9.90	28.44	28.44	16.51	-904
DTBS 6-6U	3/8	9.52	9/16-18	7.11	5/8	15.87	11/16	17.46	11/16	17.46	16.76	19.30	24.63	11.17	32.00	32.25	20.06	-906
DTBS 8-8U	1/2	12.70	3/4-16	10.41	13/16	20.64	7/8	22.22	7/8	22.22	22.86	21.84	27.43	12.70	37.59	37.84	25.65	-908
DTBS12-12U	3/4	19.05	1-1/16-12	15.74	1-1/8	26.98	1-1/8	28.58	1-1/4	31.75	24.38	21.84	31.24	16.76	41.40	48.76	36.57	-912
DTBS16-16U	1	25.40	1-5/16-12	22.35	1-3/8	34.92	1-1/2	38.10	1-1/2	38.10	31.24	26.41	38.35	16.76	50.54	53.59	43.94	-916
DTBS 20-20U	1-1/4	31.75	1-5/8-12	27.68	1-11/16	42.86	1-7/8	47.63	1-7/8	47.63	41.14	38.86	45.72	16.76	67.81	58.16	54.86	-920
DTBS 24-24U	1-1/2	38.10	1-7/8-12	34.03	2	50.80	2-1/4	57.15	2-1/8	53.98	50.03	45.21	50.80	16.76	77.97	60.45	62.23	-924
DTBS 32-32U	2	50.80	2-1/2-12	45.97	2-3/4	69.85	3	76.20	2-3/4	69.85	67.56	62.73	69.85	16.76	107.18	71.62	80.26	-932

A, B & L are approximate figures in finger-tight.

O-Seal Connector

Dk-Lok O-ring seal fittings provide leak-tight sealing on both vacuum and high pressure with a smooth & flat surface perpendicular to the threaded port to ensure metal to metal contact.

The standard Buna N O-ring is contained in a precision groove to prevent O-ring extrusion at high pressure and for a controlled squeeze in a vacuum service.

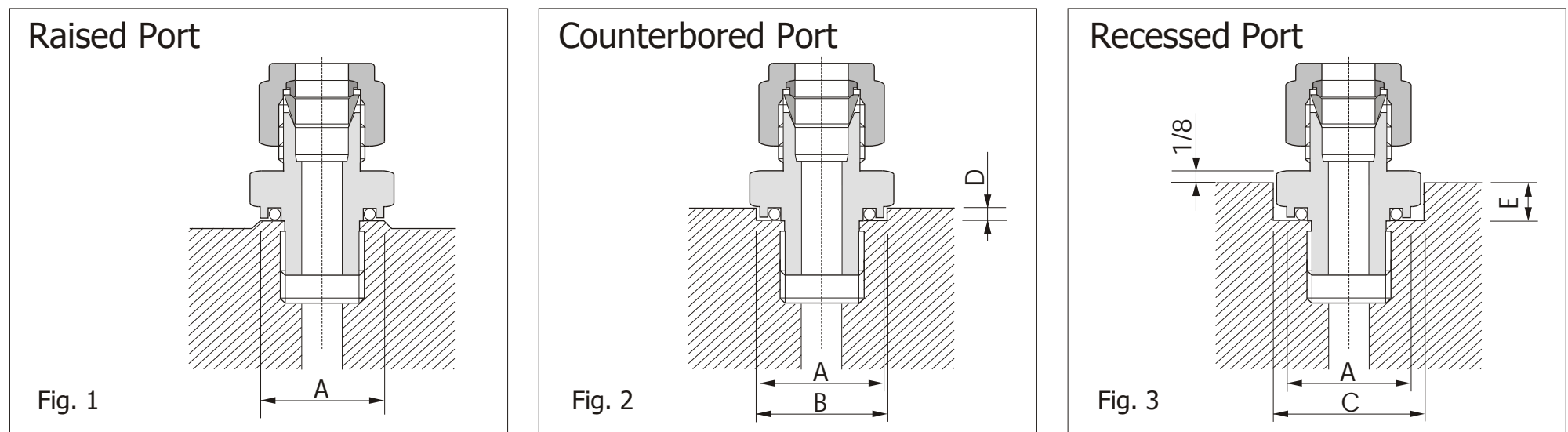

Mounting Dimensions for O-seal connectors

Dk-Lok Part No.	Straight Thread	Pipe Thread	Diameter						Depth			
			A		B		C		D		E	
			Min.		Min.		Min.		Max.		Max.	
			Inch	mm	Inch	mm	Inch	mm	Inch	mm	Inch	mm
DCOS 2-2U	5/16-24	-	0.50	12.7	0.59	15.0	0.66	16.8	0.09	2.3	0.16	5.6
DCOS 3-3U	3/8-24	-	0.56	14.2	0.66	16.8	0.75	19.1	0.09	2.3	0.22	5.6
DCOS 4-4U	7/16-20	-	0.69	17.5	0.78	19.8	0.88	22.4	0.16	4.1	0.28	7.1
DCOS 5-5U	1/2-20	-	0.75	19.1	0.91	23.1	1.03	26.2	0.16	4.1	0.31	7.9
DCOS 6-6U	9/16-18	-	0.81	20.6	0.97	24.6	1.09	27.7	0.16	4.1	0.31	7.9
DCOS 8-8U	3/4-16	-	1.00	25.4	1.16	29.5	1.31	33.3	0.16	4.1	0.34	8.6
DCOS12-12U	1-1/16-12	-	1.41	35.8	1.53	38.9	1.75	44.5	0.22	5.6	0.50	12.7
DCOS16-16U	1-5/16-12	-	1.69	42.9	1.78	45.2	2.03	51.6	0.22	5.6	0.56	14.2
DCOP 2-2	-	1/8 NPT	0.69	17.5	0.78	19.8	0.88	22.4	0.16	4.1	0.28	7.1
DCOP 4-2	-	1/8 NPT	0.69	17.5	0.78	19.8	0.88	22.4	0.16	4.1	0.28	7.1
DCOP 4-4	-	1/4 NPT	0.87	22.1	0.97	24.6	1.09	27.7	0.16	4.1	0.31	7.9
DCOP 6-6	-	3/8 NPT	1.00	25.4	1.16	29.5	1.31	33.3	0.16	4.1	0.34	8.6
DCOP 6-8	-	1/2 NPT	1.22	31.0	1.34	34.0	1.53	38.9	0.22	5.6	0.44	11.2
DCOP 8-8	-	1/2 NPT	1.22	31.0	1.34	34.0	1.53	38.9	0.22	5.6	0.44	11.2

When installing an O-ring seal fitting:

1. Hand-tighten it until the squeeze on the O-ring can be felt during the last 1/4 turn
2. Snug the fitting lightly with a wrench

When connecting & disconnecting the tubing to the O-ring fitting:

1. Use a back-up wrench on the fitting hex so it does not turn while the nut is being tightened at the tubing connection.
2. When disconnecting the tubing also use a back-up wrench so the fitting does not turn.
3. For a recessed port, use a thin back-up wrench (1/8") to hold the fitting hex (Fig. 3).

O-Seal Temperature Ratings	NBR (e.g. Perbunan [®])	-40 °C to 110 °C (-40 °F to 230 °F)
	FKM (e.g. Viton [®])	-28 °C to 204 °C (-20 °F to 400 °F)
	PTFE (e.g. Teflon [®])	-60 °C to 240 °C (-76 °F to 464 °F)

O-Seal Straight Thread Connector **DCOS**

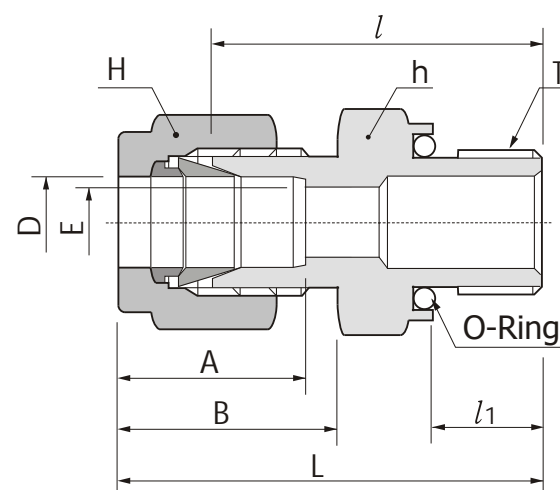
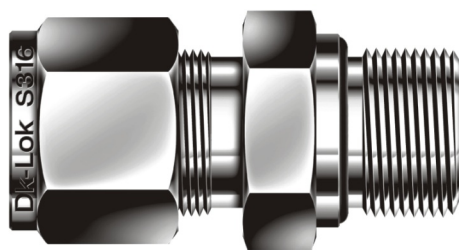

Connects fractional tube to female straight thread

Part No.	Tube O.D. D		Straight Thread T(u)	E Min.	Width across flat				A	B	l	l ₁	L	O-Ring Uniform Size Number
	in	mm			h	H	in	mm						
DCOS 2 - 2U	1/8	3.17	5/16-20	2.28	9/16	14.28	7/16	11.11	12.70	15.24	26.16	8.63	32.76	-011
DCOS 3 - 3U	3/16	4.76	3/8-24	3.04	5/8	15.87	1/2	12.70	13.71	16.00	27.68	9.65	34.29	-012
DCOS 4 - 4U	1/4	6.35	7/16-20	4.82	3/4	19.05	9/16	14.28	15.24	17.78	30.98	10.41	38.35	-111
DCOS 5 - 5U	5/16	7.93	1/2-20	6.35	7/8	22.22	5/8	15.87	16.25	18.54	33.27	11.17	40.64	-112
DCOS 6 - 6U	3/8	9.52	9/16-18	7.11	15/16	23.81	11/16	17.46	16.76	19.30	35.05	11.93	42.41	-113
DCOS 8 - 8U	1/2	12.70	3/4-16	10.41	1-1/8	28.57	7/8	22.22	22.86	21.84	35.81	11.93	45.97	-116
DCOS12 -12U	3/4	19.05	1-1/16-12	15.74	1-1/2	38.10	1-1/8	28.58	24.38	21.84	42.16	14.22	52.32	-215
DCOS16 -16U	1	25.40	1-5/16-12	22.35	1-3/4	44.45	1-1/2	38.10	31.24	26.41	45.97	14.22	58.16	-219

O-Seal Pipe Thread Connector **DCOP**

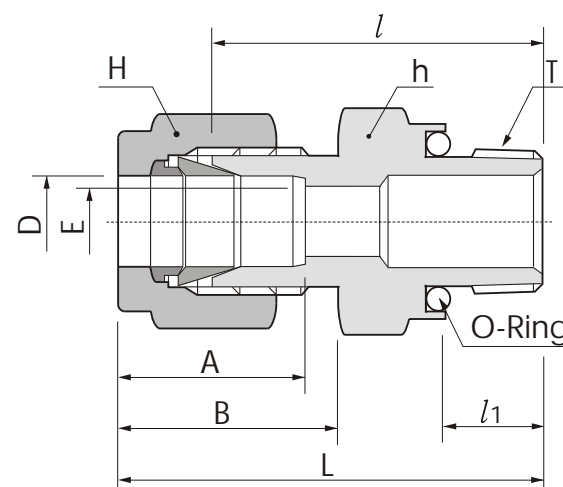
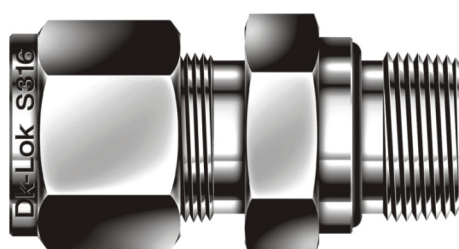

Connects fractional tube to female NPT thread

Part No.	Tube O.D. D		T *(NPT)	E Min.	Width across flat				A	B	l	l ₁	L	O-Ring Uniform Size Number
	in	mm			h	H	in	mm						
DCOP 2 - 2N	1/8	3.17	1/8	2.28	3/4	19.05	7/16	11.11	12.70	15.24	26.16	7.11	32.76	-111
DCOP 4 - 2N	1/4	6.35	1/8	4.82	3/4	19.05	9/16	14.28	15.24	17.78	27.68	7.11	35.05	-111
DCOP 4 - 4N	1/4	6.35	1/4	4.82	15/16	23.81	9/16	14.28	15.24	17.78	30.98	9.65	38.35	-113
DCOP 6 - 4N	3/8	9.52	1/4	7.11	15/16	23.81	11/16	17.46	16.76	19.30	32.51	9.65	39.87	-113
DCOP 6 - 6N	3/8	9.52	3/8	7.11	1-1/8	28.58	11/16	17.46	16.76	19.30	34.03	10.41	41.40	-116
DCOP 6 - 8N	3/8	9.52	1/2	7.11	1-5/16	33.33	11/16	17.46	16.76	19.30	39.62	13.46	46.99	-212
DCOP 8 - 8N	1/2	12.70	1/2	10.41	1-5/16	33.33	7/8	22.22	22.86	21.84	39.62	13.46	49.78	-212

* ISO Paralled Threads are available upon request.

A, B & L are approximate figures in finger-tight.

Male Pipe Weld Connector DCW

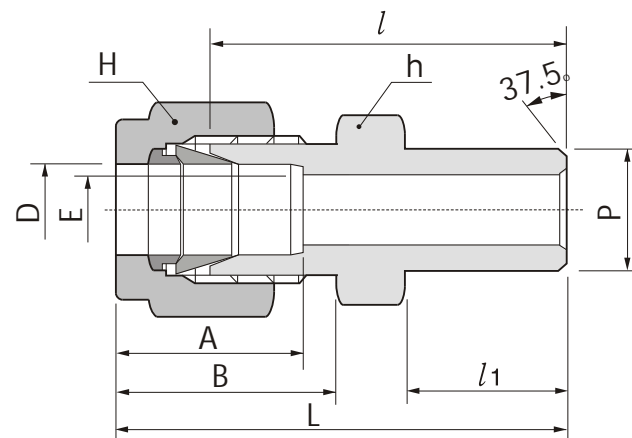
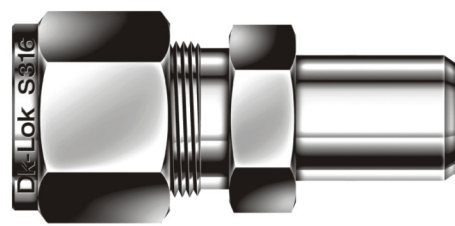

Connects fractional tube to pipe

Part No.	Tube O.D. D		Male Pipe Size P		E Min.	Width across flat				A	B	l	l ₁	L
	in	mm	Nom.	O. D.		h	H	in	mm					
DCW 2-2P	1/8	3.17	1/8	10.29	2.28	7/16	11.11	7/16	11.11	12.70	15.24	23.87	9.65	31.24
DCW 3-2P	3/16	4.76	1/8	10.29	3.04	7/16	11.11	1/2	12.70	13.71	16.00	24.63	9.65	31.24
DCW 4-2P	1/4	6.35	1/8	10.29	4.82	1/2	12.70	9/16	14.28	15.24	17.78	25.40	9.65	32.76
DCW 4-4P	1/4	6.35	1/4	13.72	4.82	9/16	14.28	9/16	14.28	15.24	17.78	30.48	14.22	37.84
DCW 5-2P	5/16	7.93	1/8	10.29	5.08	9/16	14.28	5/8	15.87	16.25	18.54	26.67	9.65	34.03
DCW 5-4P	5/16	7.93	1/4	13.72	6.35	9/16	14.28	5/8	15.87	16.25	18.54	31.24	14.22	38.60
DCW 6-4P	3/8	9.52	1/4	13.72	7.11	5/8	15.87	11/16	17.46	16.76	19.30	32.51	14.22	39.87
DCW 6-6P	3/8	9.52	3/8	17.15	7.11	11/16	17.46	11/16	17.46	16.76	19.30	32.51	14.22	39.87
DCW 6-8P	3/8	9.52	1/2	21.34	7.11	7/8	22.22	11/16	17.46	16.76	19.30	38.86	11.05	43.23
DCW 8-6P	1/2	12.70	3/8	17.15	10.41	13/16	20.64	7/8	22.22	22.86	21.84	33.27	14.22	43.43
DCW 8-8P	1/2	12.70	1/2	21.34	10.41	7/8	22.22	7/8	22.22	22.86	21.84	38.86	19.05	49.02
DCW 8-12P	1/2	12.70	3/4	26.67	10.41	1-1/16	26.98	7/8	22.22	22.86	21.84	40.38	19.05	50.54
DCW10-8P	5/8	15.87	1/2	21.34	12.70	15/16	23.81	1	25.40	24.38	21.84	38.86	19.05	49.02
DCW12-12P	3/4	19.05	3/4	26.67	15.74	1-1/16	26.98	1-1/8	28.58	24.38	21.84	40.38	19.05	50.54
DCW16-16P	1	25.40	1	33.40	22.35	1-3/8	34.92	1-1/2	38.10	31.24	26.41	50.03	23.87	62.23
DCW20-20P	1-1/4	31.75	1-1/4	42.16	27.68	1-3/4	44.45	2	50.80	41.14	38.86	55.11	23.87	77.21
DCW24-24P	1-1/2	38.10	1-1/2	48.26	34.03	2-1/8	53.98	2-1/4	57.15	50.03	45.21	61.72	26.16	88.90
DCW32-32P	2	50.80	2	60.33	47.75	2-3/4	69.85	3	76.20	67.56	62.73	76.20	26.92	113.53

Connects metric tube to pipe

Part No.	Tube O.D. D		Male Pipe Size P		E Min.	Width across flat		A	B	l	l ₁	L
	mm	mm	Nom.	O. D.		h	H					
DCW 3M-2P	3	3	1/8	10.29	2.4	12	12	12.9	15.3	23.1	9.7	29.7
DCW 4M-2P	4	4	1/8	10.29	2.4	12	12	13.7	16.1	24.1	9.7	30.7
DCW 6M-2P	6	6	1/8	10.29	4.8	14	14	15.3	17.7	25.4	9.7	32.8
DCW 6M-4P	6	6	1/4	13.72	4.8	14	14	15.3	17.7	30.2	14.2	37.6
DCW 8M-2P	8	8	1/8	10.29	5.1	15	16	16.2	18.6	26.7	9.7	34.2
DCW 8M-4P	8	8	1/4	13.72	6.4	15	16	16.2	18.6	31.2	14.2	38.7
DCW 8M-8P	8	8	1/2	21.34	6.4	22	16	16.2	18.6	37.3	19.0	44.8
DCW10M-4P	10	10	1/4	13.72	7.1	18	19	17.2	19.5	33.3	14.2	40.9
DCW10M-6P	10	10	3/8	17.15	7.9	18	19	17.2	19.5	32.5	14.2	40.1
DCW10M-8P	10	10	1/2	21.34	7.9	22	19	17.2	19.5	38.1	19.0	45.7
DCW12M-4P	12	12	1/4	13.72	7.1	22	22	22.8	22.0	33.3	14.2	43.4
DCW12M-6P	12	12	3/8	17.15	9.5	22	22	22.8	22.0	33.3	14.2	43.4
DCW12M-8P	12	12	1/2	21.34	9.5	22	22	22.8	22.0	38.1	19.0	48.2
DCW14M-6P	14	14	3/8	17.15	10.3	24	25	24.4	22.0	34.0	14.2	44.1
DCW15M-8P	15	15	1/2	21.34	11.9	24	25	24.4	22.0	38.9	19.0	49.0
DCW16M-8P	16	16	1/2	21.34	12.7	24	25	24.4	22.0	38.9	19.0	49.0
DCW18M-8P	18	18	1/2	21.34	13.5	27	30	24.4	22.0	40.4	19.0	50.5
DCW32M-20P	32	32	1-1/4	42.16	28.6	46	50	42.0	41.6	56.6	23.9	79.6
DCW38M-24P	38	38	1-1/2	48.26	33.7	55	60	49.4	47.9	64.0	26.2	91.6

Dk-Lok Welding information

Dk-Lok weld ends are constructed to Schedule 80 wall or greater.

The first step is to remove the nut and ferrules from the Dk-Lok fitting to protect them from weld heat and cover the threads with a protective device (i.e. another nut or a plug) DP to protect the Dk-Lok port threads & sealing surface from weld spatter. Only finger-tighten the protective device so that you can use it many times.

The second step is to tack weld at four positions 90 apart to hold the fitting in place to ensure alignment and concentricity of the components, then complete the weld.

Male Pipe Weld Elbow DLW

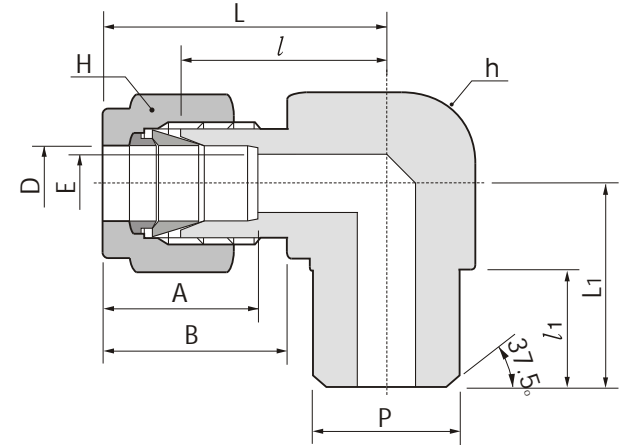
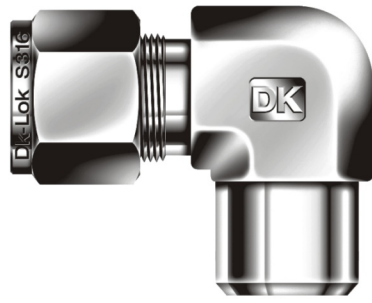

Connects fractional tube to pipe

Part No.	Tube O.D.		Male Pipe Size		E Min.	Width across flat				A	B	l	l ₁	L	L1
	D		P			h		H							
	in	mm	Nom.	O. D.		in	mm	in	mm						
DLW 2-2P	1/8	3.17	1/8	10.29	4.82	1/2	12.70	9/16	14.28	15.24	17.78	19.55	9.65	26.92	18.79
DLW 4-4P	1/4	6.35	1/4	13.72	4.82	1/2	12.70	9/16	14.28	15.24	17.78	19.55	14.22	26.92	23.36
DLW 6-4P	3/8	9.52	1/4	13.72	7.11	5/8	15.87	11/16	17.46	16.76	19.30	23.11	14.22	30.48	25.40
DLW 8-8P	1/2	12.70	1/2	21.34	10.41	13/16	20.64	7/8	22.22	22.86	21.84	25.90	19.05	36.06	33.02
DLW12-12P	3/4	19.05	3/4	26.67	15.74	1-1/16	26.98	1-1/8	28.58	24.38	21.84	29.71	19.05	39.87	36.83

Tube Socket Weld Connector DCSW

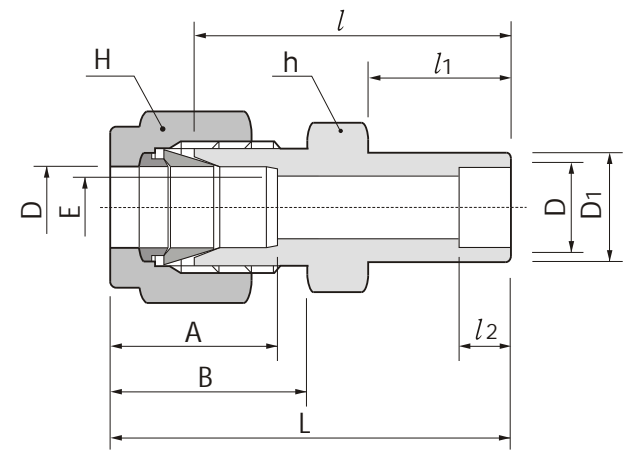
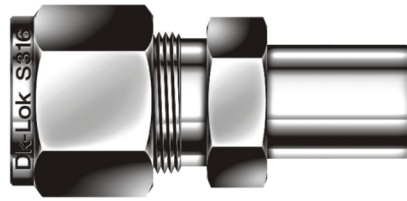

Connects fractional tubes

Part No.	Tube O. D.		E Min.	D ₁	Width across flat				A	B	l	l ₁	l ₂	L
	D				h		H							
	in	mm			in	mm	in	mm						
DCSW 2-2	1/8	3.17	2.28	7.87	7/16	11.11	7/16	11.11	12.70	15.24	22.35	8.63	6.35	28.95
DCSW 4-4	1/4	6.35	4.82	11.17	1/2	12.70	9/16	14.28	15.24	17.78	26.16	10.41	7.87	33.52
DCSW 6-6	3/8	9.52	7.11	15.74	5/8	15.87	11/16	17.46	16.76	19.30	30.22	11.93	9.65	37.59
DCSW 8-8	1/2	12.70	10.41	19.05	13/16	20.64	7/8	22.22	22.86	21.84	30.98	11.93	12.70	41.14
DCSW12-12	3/4	19.05	15.74	26.67	1-1/16	26.98	1-1/8	28.58	24.38	21.84	33.27	11.93	14.22	43.43
DCSW16-16	1	25.40	22.35	33.27	1-3/8	34.92	1-1/2	38.10	31.24	26.41	40.38	14.22	19.05	52.57

Tube Socket Weld Elbow DLSW

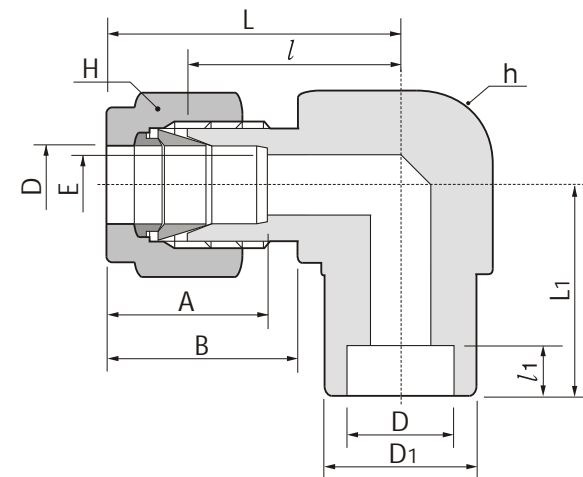
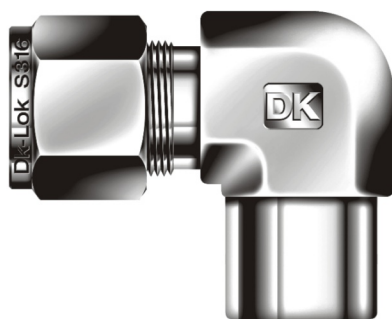

Connects fractional tubes

Part No.	Tube O. D.		E Min.	D ₁	Width across flat				A	B	l	l ₁	L	L1
	D				h		H							
	in	mm			in	mm	in	mm						
DLSW 4-4	1/4	6.35	4.82	12.70	1/2	12.70	9/16	14.28	15.24	17.78	19.55	7.87	26.92	19.55
DLSW 6-6	3/8	9.52	7.11	15.74	5/8	15.87	11/16	17.46	16.76	19.30	23.11	9.65	30.48	23.11
DLSW 8-8	1/2	12.70	10.41	20.57	13/16	20.64	7/8	22.22	22.86	21.84	25.90	12.70	36.06	25.90
DLSW12-12	3/4	19.05	15.74	26.92	1-1/16	26.98	1-1/8	28.58	24.38	21.84	29.71	14.22	39.87	29.71
DLSW16-16	1	25.40	22.35	35.05	1-3/8	34.93	1-1/2	38.10	31.24	26.41	36.83	19.05	49.02	36.83

A, B & L are approximate figures in finger-tight.

dimensions are in millimeters unless otherwise specified and only for reference subject to change.

Dk-Lok® Tube Fittings

Plug DP

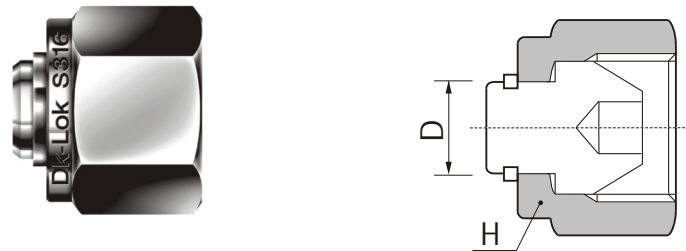

fractional

Part No.	Tube O.D. D		Width across flat H	
	in	mm	in	mm
DP-1	1/16	1.59	5/16	7.93
DP-2	1/8	3.17	7/16	11.11
DP-3	3/16	4.76	1/2	12.70
DP-4	1/4	6.35	9/16	14.28
DP-5	5/16	7.93	5/8	15.87
DP-6	3/8	9.52	11/16	17.46
DP-8	1/2	12.70	7/8	22.22
DP-10	5/8	15.87	1	25.40
DP-12	3/4	19.05	1-1/8	28.58
DP-14	7/8	22.22	1-1/4	31.75
DP-16	1	25.40	1-1/2	38.10
DP-20	1-1/4	31.75	1-7/8	47.63
DP-24	1-1/2	38.10	2-1/4	57.15
DP-32	2	50.80	3	76.20

metric

Part No.	Tube O.D. D	Width across flat H	Part No.	Tube O.D. D	Width across flat H
DP-3M	3	12	DP-18M	18	30
DP-4M	4	12	DP-20M	20	32
DP-6M	6	14	DP-22M	22	32
DP-8M	8	16	DP-25M	25	38
DP-10M	10	19	DP-28M	28	46
DP-12M	12	22	DP-32M	32	50
DP-15M	15	25	DP-38M	38	60

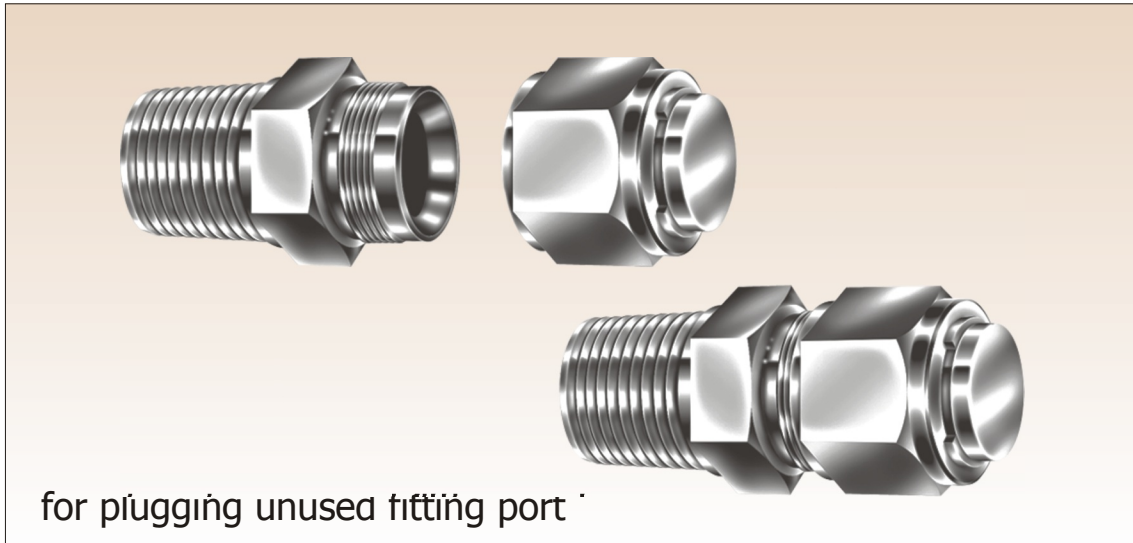

Installation Instructions

1. Remove the nut and ferrules from the body
2. With a wrench, 1/4 turn from the finger-tight position, (1/8 turn for 1/8", 3/16" and 2mm, 3mm and 4mm)

Cap DC

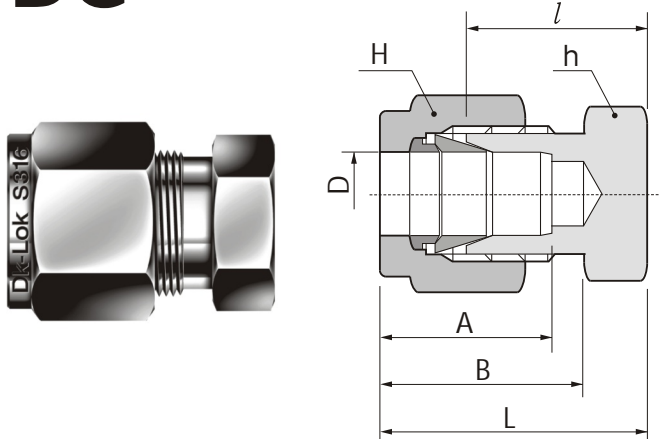

Cap end of fractional tube

Part No.	Tube O.D. D		Width across flat h		Width across flat H		A	B	l	L
	in	mm	in	mm	in	mm				
DC-1	1/16	1.59	5/16	7.93	5/16	7.93	8.63	10.92	11.20	14.18
DC-2	1/8	3.17	7/16	11.11	7/16	11.11	12.70	15.24	13.46	20.06
DC-3	3/16	4.76	7/16	11.11	1/2	12.70	13.71	16.00	14.73	21.33
DC-4	1/4	6.35	1/2	12.70	9/16	14.28	15.24	17.78	16.00	23.26
DC-5	5/16	7.93	9/16	14.28	5/8	15.87	16.25	18.54	17.01	24.38
DC-6	3/8	9.52	5/8	15.87	11/16	17.46	16.76	19.30	18.28	25.65
DC-8	1/2	12.70	13/16	20.63	7/8	22.22	22.86	21.84	19.05	29.21
DC-10	5/8	15.87	15/16	23.81	1	25.40	24.38	21.84	19.81	29.97
DC-12	3/4	19.05	1-1/16	26.98	1-1/8	28.57	24.38	21.84	21.33	31.49
DC-14	7/8	22.22	1-3/16	30.16	1-1/4	31.75	25.90	21.84	23.87	34.03
DC-16	1	25.40	1-3/8	34.92	1-1/2	38.10	31.24	26.41	26.16	38.35
DC-20	1-1/4	31.75	1-3/4	44.45	1-7/8	47.63	41.14	38.86	31.24	53.34
DC-24	1-1/2	38.10	2-1/8	53.98	2-1/4	57.15	50.15	45.21	37.33	64.51
DC-32	2	50.80	2-3/4	69.85	3	76.20	67.56	62.73	49.27	86.61

Installation Instructions

1. Insert the tube end into the Cap
2. With a wrench, 1-1/4 turns from the finger-tight position, (3/4 turn for 1/8", 3/16" 3mm and 4mm)

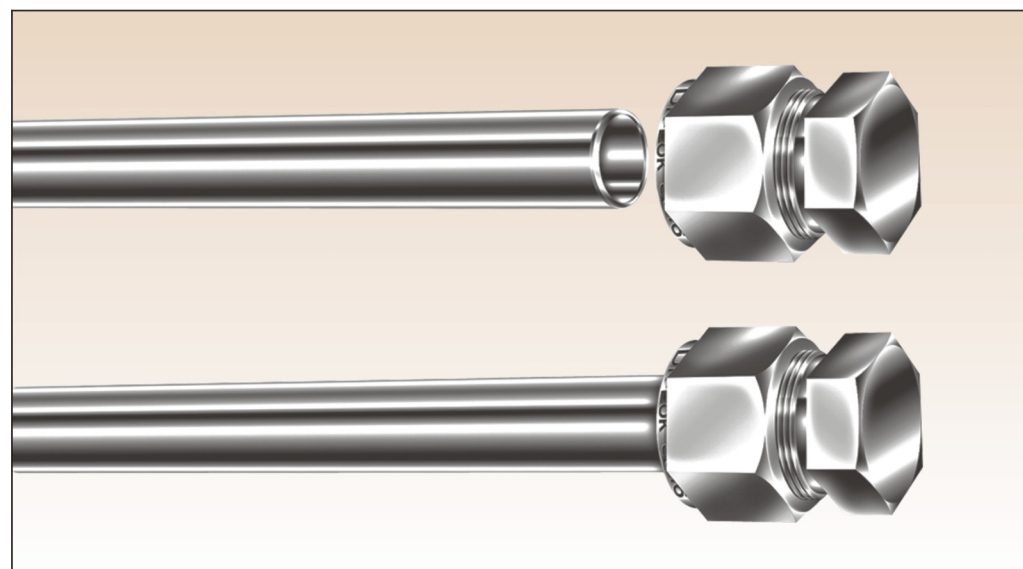

Cap end of metric tube

Part No.	Tube O.D. D	Width across flat		A	B	l	L
		h	H				
DC-2M	2	12	12	12.9	15.3	13.5	20.1
DC-3M	3	12	12	12.9	15.3	13.5	20.1
DC-4M	4	12	12	13.7	16.1	14.7	21.3
DC-6M	6	14	14	15.3	17.7	15.7	23.1
DC-8M	8	15	16	16.2	18.6	17.0	24.5
DC-10M	10	18	19	17.2	19.5	19.0	26.6
DC-12M	12	22	22	22.8	22.0	19.0	29.1
DC-15M	15	24	25	24.4	22.0	19.8	29.9
DC-16M	16	24	25	24.4	22.0	19.8	29.9
DC-18M	18	27	30	24.4	22.0	21.3	31.4
DC-20M	20	30	32	26.0	22.0	23.9	34.0
DC-22M	22	30	32	26.0	22.0	23.9	34.0
DC-25M	25	35	38	31.3	26.5	26.2	38.5
DC-28M	28	41	46	36.6	36.6	27.7	48.5
DC-32M	32	46	50	42.0	41.6	32.8	55.8
DC-38M	38	55	60	49.4	47.9	37.8	65.4

Tube Insert DI

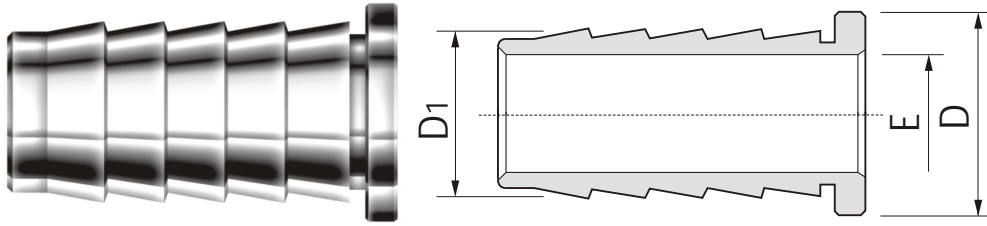

for Nylon or Soft Plastic Tubing

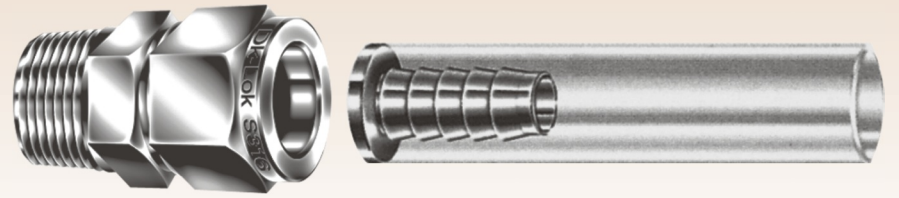

fractional

Part No.	Tube O.D.				E
	D		D1		
	in	mm	in	mm	
DI 3-2	3/16	4.76	1/8	3.17	2.28
DI 4-2	1/4	6.35	1/8	3.17	2.28
DI 4-3	1/4	6.35	3/16	4.76	3.55
DI 5-2	5/16	7.93	1/8	3.17	2.28
DI 5-3	5/16	7.93	3/16	4.76	3.04
DI 5-4	5/16	7.93	1/4	6.35	4.82
DI 6-3	3/8	9.52	3/16	4.76	3.04
DI 6-4	3/8	9.52	1/4	6.35	4.82
DI 8-4	1/2	12.7	1/4	6.35	4.82
DI 8-6	1/2	12.7	3/8	9.52	7.87
DI 10-6	5/8	15.87	3/8	9.52	7.87
DI 10-8	5/8	15.87	1/2	12.70	11.17
DI 12-8	3/4	19.05	1/2	12.70	11.17
DI 12-10	3/4	19.05	5/8	15.87	14.22
DI 16-12	1	25.4	3/4	19.05	17.52

Installation Instructions

The Dk-Lok Tube Insert supports the soft plastic tubing, thus the tubing does not collapse when the ferrules deform it. When you select a size of Tube Insert, check if the tubing O.D. and I. D. conform to those of the tube insert.

metric

Part No.	Tube O.D.		E
	D	D1	
DI 6M-4M	6	4	2.8
DI 8M-6M	8	6	4.4
DI 10M-8M	10	8	6.4
DI 12M-8M	12	8	6.4
DI 12M-10M	12	10	8.3

Nut DN

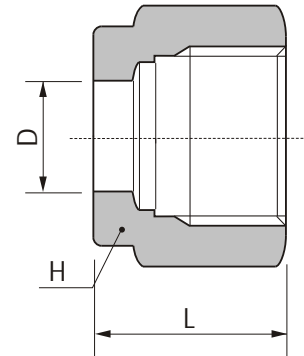

fractional

Part No.	Tube O.D.		Width across flat		L
	D		H		
	in	mm	in	mm	
DN-1	1/16	1.59	5/16	7.93	7.90
DN-2	1/8	3.17	7/16	11.11	11.93
DN-3	3/16	4.76	1/2	12.70	11.93
DN-4	1/4	6.35	9/16	14.28	12.70
DN-5	5/16	7.93	5/8	15.87	13.46
DN-6	3/8	9.52	11/16	17.46	14.22
DN-8	1/2	12.70	7/8	22.22	17.52
DN-10	5/8	15.87	1	25.40	17.52
DN-12	3/4	19.05	1-1/8	28.57	17.52
DN-14	7/8	22.22	1-1/4	31.75	17.52
DN-16	1	25.40	1-1/2	38.10	20.57
DN-20	1-1/4	31.75	1-7/8	47.63	31.75
DN-24	1-1/2	38.10	2-1/4	57.15	38.10
DN-32	2	50.80	3	76.20	52.32

metric

Part No.	Tube O.D.	Width across flat	L
	D	H	
DN - 2M	2	12	11.90
DN - 3M	3	12	11.90
DN - 4M	4	12	11.90
DN - 6M	6	14	12.70
DN - 8M	8	16	13.50
DN - 10M	10	19	15.10
DN - 12M	12	22	17.40
DN - 15M	15	25	17.40
DN - 16M	16	25	17.40
DN - 18M	18	30	17.40
DN - 20M	20	32	17.40
DN - 22M	22	32	17.40
DN - 25M	25	38	20.60
DN - 28M	28	46	30.60
DN - 32M	32	50	34.40
DN - 38M	38	60	40.60

A, B & L are approximate figures in finger-tight.

Dk-Lok[®] Tube Fittings

Front Ferrule DFF

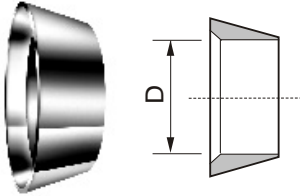

fractional

Part No.	Tube O.D. D	
	in	mm
DFF-1	1/16	1.59
DFF-2	1/8	3.17
DFF-3	3/16	4.76
DFF-4	1/4	6.35
DFF-5	5/16	7.93
DFF-6	3/8	9.52
DFF-8	1/2	12.70
DFF-10	5/8	15.87
DFF-12	3/4	19.05
DFF-14	7/8	22.22
DFF-16	1	25.40
DFF-20	1-1/4	31.75
DFF-24	1-1/2	38.10
DFF-32	2	50.80

metric

Part No.	Tube O.D. D
DFF-2M	2
DFF-3M	3
DFF-4M	4
DFF-6M	6
DFF-8M	8
DFF-10M	10
DFF-12M	12
DFF-15M	15
DFF-16M	16
DFF-18M	18
DFF-20M	20
DFF-22M	22
DFF-25M	25
DFF-28M	28
DFF-32M	32
DFF-38M	38

Back Ferrule DFB

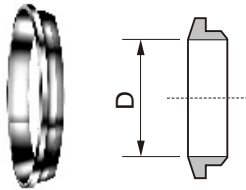

fractional

Part No.	Tube O.D. D	
	in	mm
DFB-1	1/16	1.59
DFB-2	1/8	3.17
DFB-3	3/16	4.76
DFB-4	1/4	6.35
DFB-5	5/16	7.93
DFB-6	3/8	9.52
DFB-8	1/2	12.70
DFB-10	5/8	15.87
DFB-12	3/4	19.05
DFB-14	7/8	22.22
DFB-16	1	25.40
DFB-20	1-1/4	31.75
DFB-24	1-1/2	38.10
DFB-32	2	50.80

metric

Part No.	Tube O.D. D
DFB-2M	2
DFB-3M	3
DFB-4M	4
DFB-6M	6
DFB-8M	8
DFB-10M	10
DFB-12M	12
DFB-15M	15
DFB-16M	16
DFB-18M	18
DFB-20M	20
DFB-22M	22
DFB-25M	25
DFB-28M	28
DFB-32M	32
DFB-38M	38

Ferrule Set DFS



fractional

Part No.	Tube O.D.	
	in	mm
DFS-1	1/16	1.59
DFS-2	1/8	3.17
DFS-3	3/16	4.76
DFS-4	1/4	6.35
DFS-5	5/16	7.93
DFS-6	3/8	9.52
DFS-8	1/2	12.70
DFS-10	5/8	15.87
DFS-12	3/4	19.05
DFS-14	7/8	22.22
DFS-16	1	25.40

metric

Part No.	Tube O.D.
DFS-2M	2
DFS-3M	3
DFS-4M	4
DFS-6M	6
DFS-8M	8
DFS-10M	10
DFS-12M	12
DFS-15M	15
DFS-16M	16
DFS-18M	18
DFS-20M	20
DFS-22M	22
DFS-25M	25

Gap Gauge for Pull-up Inspection DIG

Dk-Lok maintains unbelievably tight tolerance on its each and every part. Dk-Lok tube fittings are monitored and gauged throughout process. This assures Dk-Lok consistency and makes Dk-Lok fittings gaugable.

This no-go gauge is the useful tool to inspect if the fittings are pulled up 1-1/4 turns from the finger-tight position. When the gauge doesn't fit the gap between the nut and body hex, the fitting is tightened 1-1/4 turns from the finger-tight position. If the gauge fits the gap, the fittings is not fully tightened.

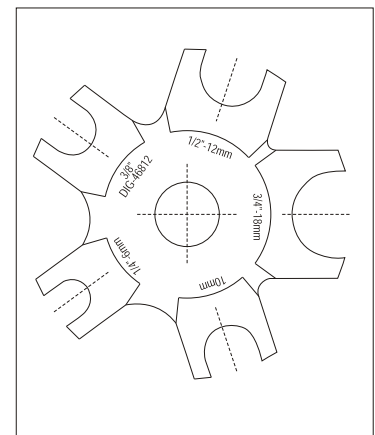

Multiple Size Gap Gauge

Part No.	Applicable Dk-Lok Tube O.D.
DIG 468	1/4", 3/8", 1/2", 6mm, 10mm, 12mm

DHS-1A

Dk-Lok[®] Hydraulic Swaging Unit

Model No. DHS-1A

For over 1" Stainless steel and Carbon Steel Dk-Lok fittings

Dk-Lok[®] offers a unique & versatile Swaging unit that is easy to operate and allows pre-swaging for 1/2" to 2" (12mm to 38mm). It will save you time and money and even storage space. From now on, hand carry only one unit not many.

Our Dk-Lok[®] Swaging unit is designed to pre-swage the front & back ferrule onto the tubing prior to final assembly into a fitting with little physical effort other than the manual pull-up. This unit provides consistent make-up and a reliable leak-free seal. Swaging dies are available from 1/2" to 2" (12mm to 38mm).

The Dk-Lok[®] Swaging unit consist of a Hydraulic hand pump, Pump hose, swaging head and swaging dies and are contained in the sturdy steel case.

Swaging unit

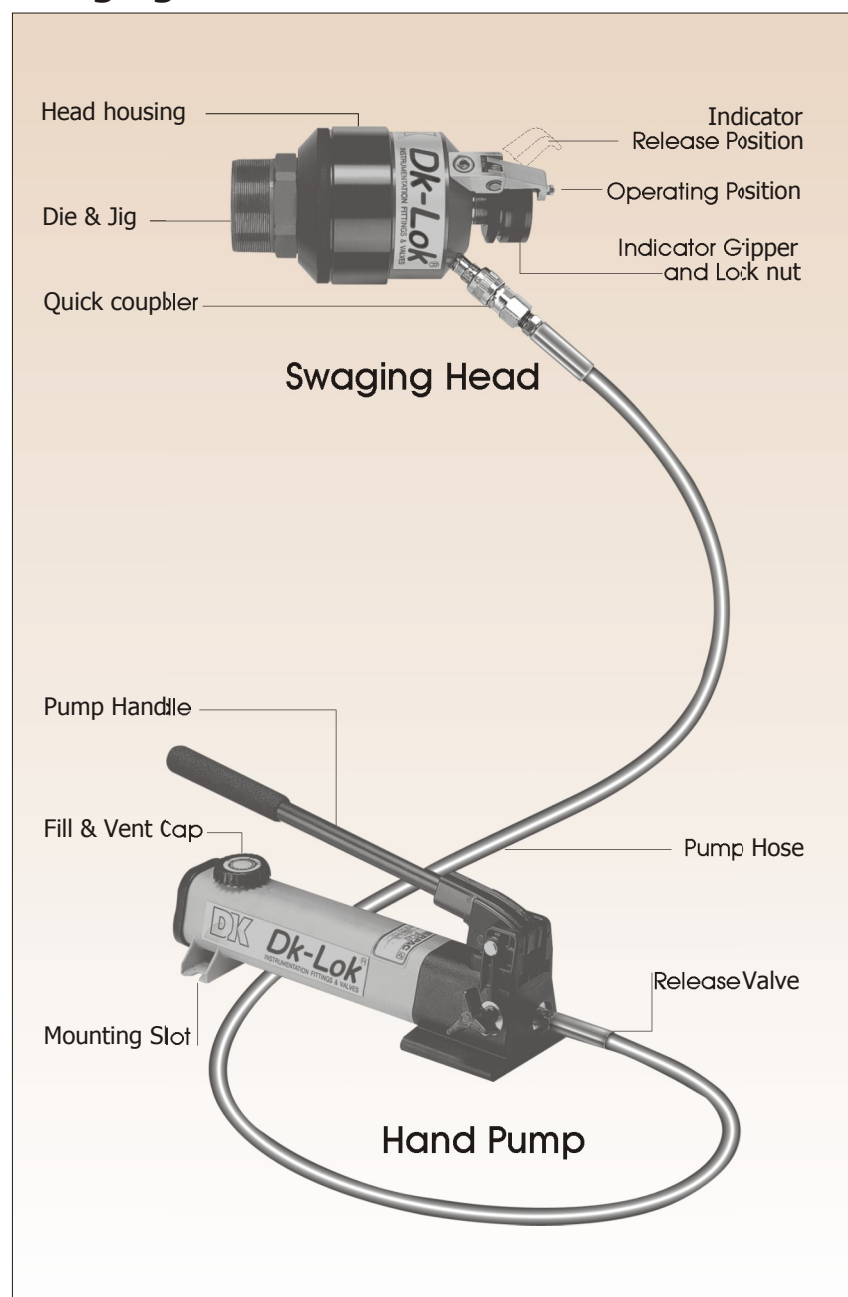

DHS-1A part list, part number and standard Qty

No.	Part List	Part No.	Qty
1	Steel Case	DHS-1C	1
2	Die & Jig Case	DHS-1CD	1
3	Swaging Head	DHS-1SH	1
4	Hand Pump	DHS-1HP-10K	1
5	Pump Hose	DHS-1PS-1.2M	1
6	Die & Jig	See below	-
7	Die fixing bolt	DHS-1B- 8M	1
8	8mm Allen key	DHS-1K-8M	1
9	Ratchet wrench	DHS-1RW	1
10	Operating manual	DHS-1A manual	1

Die, Jig and recommended tubing wall thickness

Dk-Lok Fitting	Die Part No.	Jig Part No.	Die & Jig Set Part No.	Recommended Min. & Max. Wall Thickness			
				S316 Tubing		Carbon Steel Tubing	
				Min.	Max.	Min.	Max.
1/2"	D8	J8	DJS8	0.049"	0.083"	0.049"	0.083"
5/8"	D10	J10	DJS10	0.065"	0.095"	0.065"	0.095"
3/4"	D12	J12	DJS12	0.083"	0.109"	0.083"	0.109"
1"	D16	J16	DJS16	0.083"	0.120"	0.083"	0.120"
1-1/4"	D20	J20	DJS20	0.083"	0.156"	0.065"	0.180"
1-1/2"	D24	J24	DJS24	0.095"	0.188"	0.083"	0.220"
2"	D32	J32	DJS32	0.109"	0.188"	0.095"	0.220"

Note : For metric Dies and Jigs, suffix M to the designated size. e.g. D25M and J25M for 25mm die & Jig.

How to Order

Please order our Unit No. DHS-1A and specify the fitting sizes.

e.g. DHS-1A and 3/4", 1", 1-1/4", 1-1/2", 2". Then the die and Jig Set of DJS12, DJS16, DJS20, DJS24 and DJS32 shall be included in the steel case.

Note : The steel case is designed to contain 6 sets of die and Jig maximum.

When you need more than 6 sets of die and Jig, you will need to order the special Die & Jig case No. DHS-1CD.

A, B & L are approximate figures in finger-tight.

INSTALLATION INSTRUCTIONS

Dk-Lok is supplied finger-tight and ready for immediate use. Therefore fitting disassembly is not necessary for installation.

Step 1.

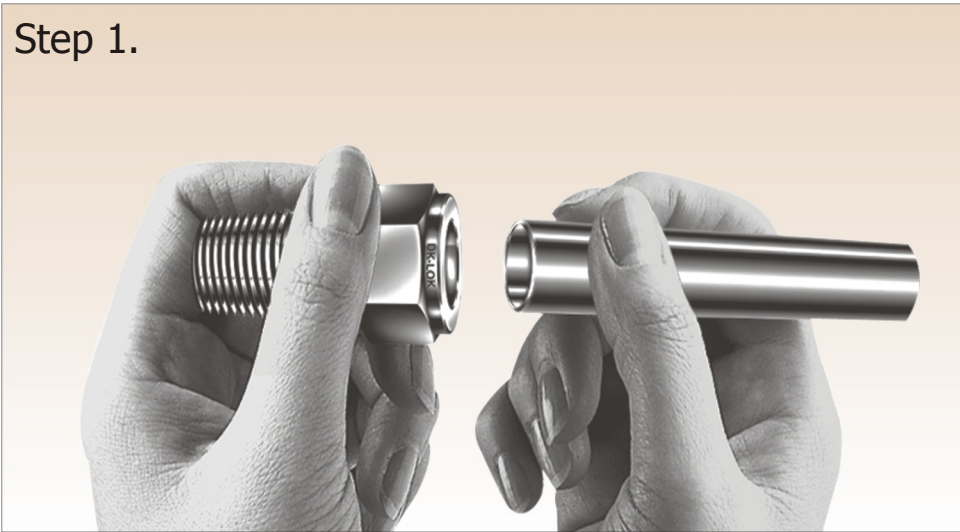

Make sure the nut is finger-tight. Put the tubing into the Dk-Lok tube fitting until the tube end bottoms on the shoulder inside the fitting.

Step 2.

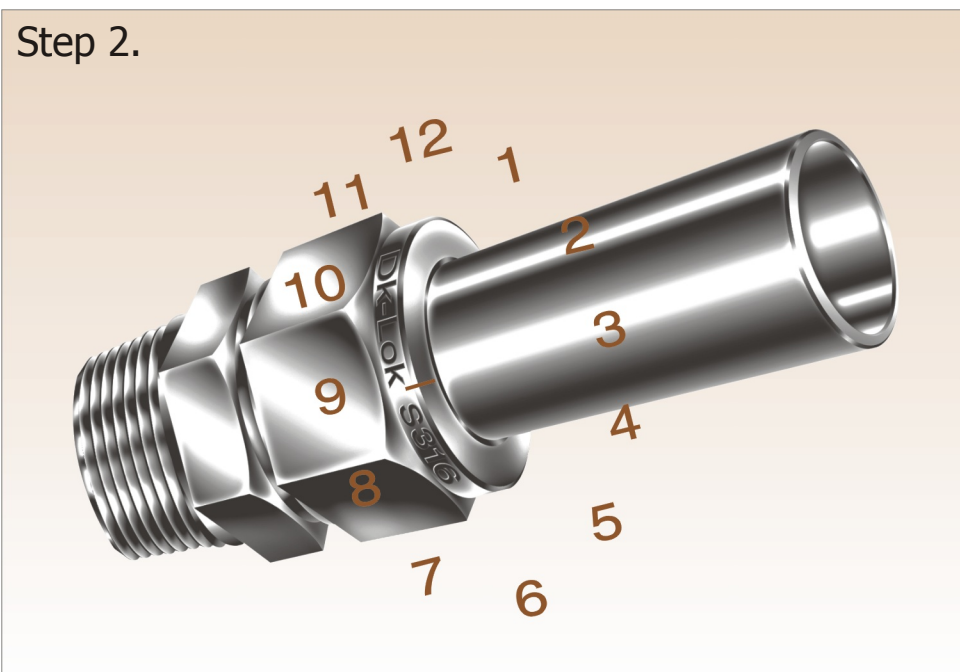

Tighten the nut 1-1/4 turn with a wrench by holding the fitting body with a back up wrench.

Marking the nut at the 9:00 o' clock position may be necessary for counting the number of turns as the mark will stop at the 12 o' clock position after 1 -1/4 turns.

*Only 3/4 turn from finger tight is required for sizes 1/8", 3/16", 3mm and 4mm.

Re-assembly Instructions

Dk-Lok connections can be used many times. Prior to re-assembly, ensure the components are clean and free of defects.

Step 1.

Insert the tubing with pre-swaged ferrules and a nut into the body until the front ferrule seats firmly in the fitting body.

Step 2.

Hand tighten the nut. Then rotate the nut with a wrench to the original 1-1/4 tight position (sharp rise in torque is felt at the original position) and snug slightly with a wrench.

Tube handling during installation

1. Do not force the tubing into the fitting when it does not smoothly go in. It may be a deformed oval or have burs at the tubing end.
2. It is important to use the proper tube cutter and maintain a sharp cutting wheel on it always.

Proper Tube Handling

Good handling practices can greatly save the good surface finish of the tubing supplied.

- * Tubing should be stored vertically not horizontally to avoid collection of dirt and contamination. Cover the tubing when you have to keep horizontally.
- * Tubing should never be dragged across cement, asphalt, gravel or any other rough surface.
- * Tubing should never be dragged out of a tubing rack.
- * Tube cutter wheel and hacksaw blade should always be sharp.
- * Try not to take deep cuts with each turn of the cutter or stroke of the saw.
- * Tube ends should always be deburred
- * If possible, tubing ends should be plugged so any foreign materials will not fall inside.
- * Nylon or soft plastic tubing should use Tube Insert (DI) as sealing on the O.D. of the tubing needs a certain amount of tube resistance for a tight seal.

These help assure the tubing goes all the way through the fitting without damaging Dk-Lok sealing system.

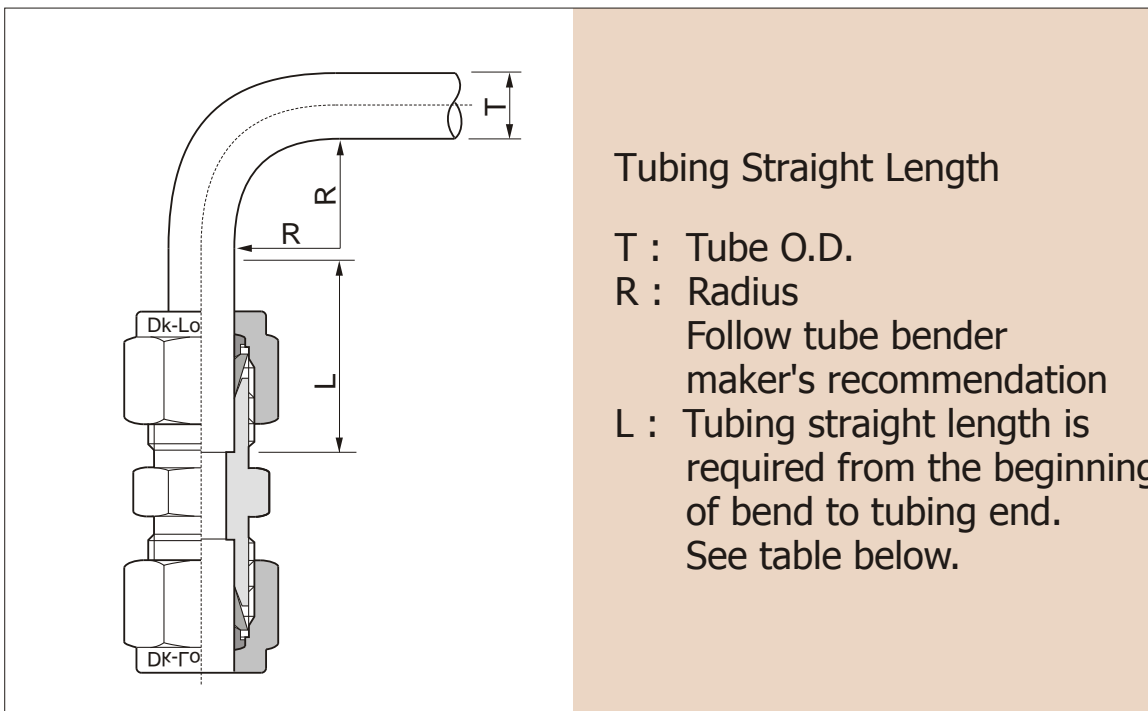

Tube Bending

When tube bend is too close to a fitting, the deformed section at bend shall enter the fitting and it may result in leaks. Therefore keep the proper straight length of tube from fitting as shown in tables below.

Straight length of Fractional tubing

Unit : Inch

Tube O. D.		1/16	1/8	3/16	1/4	5/16	3/8	1/2	5/8	3/4	7/8	1	1-1/4	1-1/2	2
Straight Length	L1	2/1	23/32	3/4	13/16	7/8	15/16	13/16	1-1/4	1-1/4	1-5/16	1-1/2	2	2-13/32	3-1/4
	L2	13/32	19/32	5/8	11/16	23/32	3/4	31/32	1-1/32	1-1/32	1-3/32	1-9/32	1-13/16	2-7/32	3-1/32

Straight length of Metric tubing

Unit : mm

Tube O. D.		3	6	8	10	12	14	16	18	20	22	25	32	38
Straight Length	L1	19	21	23	25	31	32	32	32	34	34	40	51	60
	L2	16	17	18	20	24	25	25	25	26	27	33	47	55

Note : L 1 = Recommended straight length of tubing required
 L 2 = Absolute minimum straight length of tubing required